

Manual BlueSense Transducer



Copyright

According to the protective notes of DIN ISO 16016

"The reproduction, distribution and utilization of this document as well as the communication of its contents to others without express authorization are prohibited. Offenders will be held liable for the payment of damages. All rights reserved in the event of patent, utility model or design registration."

Changes

GO Systemelektronik GmbH retains the right to modify the contents of the manual without prior notice.

Liability exclusion

GO Systemelektronik GmbH takes no responsibility for correct system operation under all possible operating conditions. It is not possible to guarantee that the software will function completely without error under all possible circumstances. GO Systemelektronik GmbH therefore disclaims all liability for any direct or indirect damage resulting from system operation or the contents of this manual.

Product observance

Within the scope of our obligation for product observance GO Systemelektronik GmbH will endeavour to warn third parties about all identified dangers which could arise from the interaction between hardware and software and from the use of other components. Effective product observance is only possible with adequate information from the end user about the planned field of application and the hardware and software used. If the conditions of use change or if the hardware or software is changed, due to the complex relationships between hardware and software, it is no longer possible to describe all possible dangers and their effects on the total system, in particular on our system. This manual does not describe every possible property and combination of the system. For further information, please contact GO Systemelektronik GmbH.

Manufacturer's declaration

When installing the system it is necessary to ensure correct electrical connection, protection against moisture and foreign bodies and excessive condensation, and system heating which can arise from both correct and incorrect use. It is the responsibility of the installer to ensure that the correct installation conditions are provided

Transportation Note for Distributors



Transportation note for distributors:

Avoid exposing the BlueSense Transducer to ionizing radiation.

In the case of transnational transport routes and the associated controls, it is possible that a BlueSense transducer is exposed to a too high dose of X-radiation and, as a result, stored values in the EEPROMs of the sensor plug-in cards may be affected.

Procedure before delivery:

- **Switch on BlueSense transmitter.**
- **Call up the calibration coefficients menu.**
[Menu] ⇒ [Setup] ⇒ [Service] ⇒ *Input Service password** ⇒
[Sensor name] ⇒ [C0...C5] [C6...C7]
Repeat with the following sensors if necessary.
- **Compare the calibration coefficients with the supplied sensor setup protocols and, if necessary, correction of the calibration coefficients.**

* The necessary service password can be found in the enclosed Device Setup Sheet.

Table of Contents

1 Overview.....6

2 Technical Data and Connection Diagrams8

 2.1 Technical Data8

 2.2 Connection Diagram 1 Control Parameter.....9

 2.3 Connection Diagram 2 Control Parameter.....10

 2.4 Sensor Terminal Connection Diagram11

 2.5 Notes on the Pulse/Digital Inputs.....12

3 Hazard Note12

4 Turning On the System13

 4.1 Parameter Display and Main Menu.....13

 4.1.1 Parameter Display.....13

 4.1.1.1 Menu Password Prompt14

 4.1.2 Main Menu.....15

5 Setup.....16

 5.1 Sensors.....17

 5.1.1 Oxygen Sensor Setup (Control Parameter).....18

 5.1.1.1 Sensor Calibration19

 5.1.1.1.1 Example One-Point-Calibration19

 5.1.1.1.2 Example Two-Point-Calibration.....20

 5.1.1.2 Relay Setup21

 5.1.1.3 Current Output Setup22

 5.1.1.4 Change Name.....23

 5.1.1.5 Parameter23

 5.1.1.5.1 Minimum Value and Maximum Value24

 5.1.1.5.2 Average and Interval.....25

 5.1.2 Temperature Sensor Setup (Associated Parameter)26

 5.1.3 Digital In.....26

 5.2 Reset.....27

 5.3 Comport.....28

 5.3.1 Protocol Selection29

 5.3.2 Modbus Address Input.....29

 5.4 Language Setting.....30

 5.5 Time/Date31

6 Screen.....32

7 Memory Card.....33

 7.1 Save Data.....33

 7.2 Adjustment of the Storage Interval.....34

 7.3 Update (Firmware).....34

 7.4 Read Data35

8 Programs.....36

 8.1 Flushcontrol Parameters.....37

 8.2 Parameter PID.....38

 8.2.1 Parameter PID (Sensor selection).....40

9 Info Transducer.....	40
10 Installation Notes	41
11 Maintenance Instructions.....	41
Appendix A – Modbus.....	42
Appendix B – Connection to a BlueBox	46
Appendix C – Adjustment of the Touch Display	47
Appendix D – Housing Dimensions	48
Appendix E – Status and Error Messages	49
Appendix F – Multipoint Calibration.....	51
Appendix G – Menu Structure.....	53
Commissioning of the BlueSense Transducer	56
CBB 1 Notes on Operation	57
CBS 2 Commissioning	58
CBS 3 EU Declaration of Conformity	59

1 Overview

This user manual describes a BlueSense Transducer.



The Transducer

- receives the signals of the connected sensors,
- generates there from measurement values,
- displays the measurement values,
- transduces the measurement values into analogue current values (4 – 20 mA),
- transmits the current values to a signal processing systems,
- transmits the measurement values via CAN-bus to a BlueBox or is able to network with PLC¹-Systems via RS232 or RS485 or Profibus[®],
- stores the measurement values on a SD Memory Card,
- switches relays by overrun or underrun of settable alarm values,
- converts the measurement values of a conductivity sensor into salinity²,
- switches two internal relays at adjustable times (here called Flushcontrol),
- executes a relay control program and a PID controller
- and executes customer-specific programs.

Connectable sensors and measurement inputs:

- | | |
|---|--|
| • Conductivity: measuring principle: inductive with integrated temperature sensor: measuring principle: NTC | 0 – 120 mS/cm 0 – 4000 µS/cm
0 to 80 °C |
| • Temperature: measuring principle: NTC
Standard temperature sensor 83k3NTC | -5 to +80 °C
25°C ± 83 kΩ |
| • Dissolved oxygen: measuring principle: galvanic cell | 0 – 20 mg/l |
| • Dissolved oxygen: measuring principle: fluorescence | 0 – 20 mg/l |
| • pH glass electrode | pH 3 – pH 13 |
| • Ion-selective electrode | |
| • Turbidity submersible: scattered light 90°, wave length 860 nm | 0 – 3000 FNU |
| • Turbidity flow through: scattered light 90°, wave length 860 nm | 0 – 100 FNU |
| • ORP | -2000 to +2000 mV |
| • Current input, resistance 50 Ω | 4 – 20 mA |
| • Voltage input | 0 – 5 V 5 – 50 V |
| • All established sensors with current or voltage outputs, e.g. Cl, ClO ₂ , NH ₄ , etc. | |
| • Modbus sensors | |

The number of sensors that can be connected is determined by the delivered Transducer configuration. There are two configurations:



- **1 Control parameter = 1 analogue input**
One sensor is connected. One control parameter is measured and where applicable the temperature as an associated parameter.
- **2 Control parameters = 2 analogue inputs**
Two sensors are connected. Two control parameters are measured and where applicable the temperature for each sensor as associated parameters.

¹ Programmable Logic Controller

² Salinity according to the general formula of the UNESCO for seawater

BlueSense

To determine if your Transducer has 1 or two 2 control parameters please refer to the shipping note, the serial number of the transducer is on the right hand side of the housing.

 GO Systemelektronik GmbH Made in Germany		
Type: BlueSense	Art. No.: 485 0001	
Power supply:	230 VAC	
SN: 1234	39/27	
<small>GO Systemelektronik GmbH 24109 Kiel Tel.: +49 431 58080-0</small>		<small>24109 Kiel Tel.: +49 431 58080-0</small>
<small>Fax: +49 431 58080-11 info@go-sys.de</small>		<small>ww w.go-sys.de</small>

The transducer can store the states of the inputs (and therefore also the measured values) and the error messages on an SD Memory Card. The Transducer itself has no data storage.

The transducer is operated via a touch-sensitive screen (touch display). For example, you can calibrate sensors and set switching values in just a few steps.

The menu steps are displayed in plain text and are therefore easy to understand.

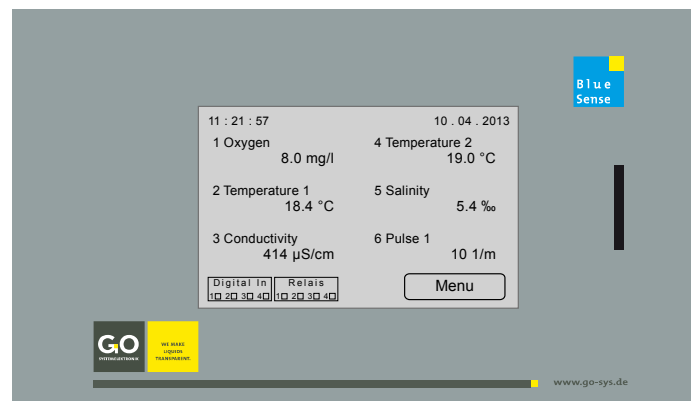

Basic structure of the menu navigation:

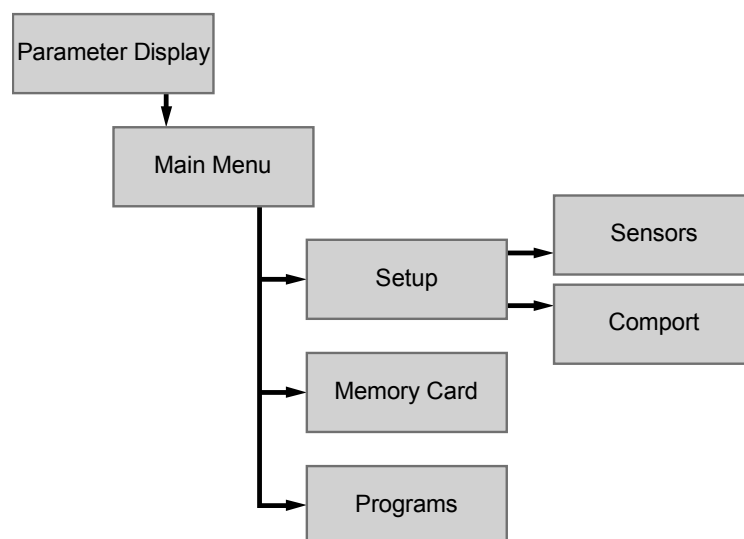

see Appendix G – Menu Structure

2 Technical Data and Connection Diagrams

2.1 Technical Data

Article-Nr. 485 0001-X



Inputs:

- 1 or 2 analogue inputs (1 Control parameter or 2 Control parameters)
The particular configuration is on the shipping note, the serial number of the transducer is on the type plate at the right hand side of the housing.
- 2 pulse inputs, selectable to PNP/NPN (also statically usable), switching current approx. 6 mA, measurement range 0.05 Hz – 1000 Hz
- 2 digital inputs (static), potential-free contacts, switching current approx. 6 mA

 GO Systemelektronik GmbH Made in Germany		
Type: BlueSense	Art. No.: 485 0001	
Power supply:	230 VAC	
SN: 1234	39/27	
<small>GO Systemelektronik GmbH 24109 Kiel Tel.: +49 431 58080-0 Fax: +49 431 58080-11 info@go-sys.de ww w.go-sys.de</small>		

Outputs:

- 2 current outputs (4 to 20 mA), active
- 2 relays with a switching capacity of 24 V / 0.5 A (resistive load)
- 2 relays with a switching capacity of 230 VAC / 2 A (resistive load) or 24 VDC / 6 A (resistive load)

Communications interfaces:*

- CAN-bus connector for connection to the BlueBox-System
or
- RS232 or RS485, each with 9600 Baud, Modbus
or
- Profibus®

Voltage feed:*

- 12 VDC (9 – 18 VDC), received power max. 15 W
or
- 24 VDC (18 – 36 VDC), received power max. 15 W
or
- 230 VAC (90 – 260 VAC), received power max. 10 W



To avoid incorrect measurements, the PE contact of the power supply (slot X10) must be connected.

Display: LCD Touch Panel: 240 x 128 pixels; secure temperature range -10 to +45 °C

Housing: Polycarbonate, 235 mm x 185 mm x 119 mm; protection code IP65; secure temperature range -10 to +45 °C

Weight: 1.35 kg

* The equipment of your transducer is documented on the sticker on the inside of the cover for the cable connections.

2.2 Connection Diagram 1 Control Parameter

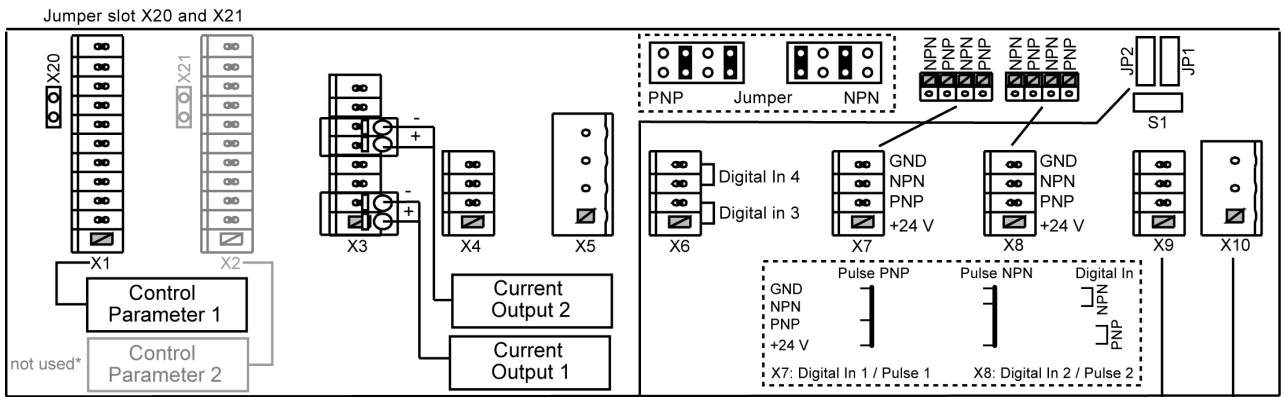

*Exclusion conductivity sensor, here is X1 not used and X2 is used

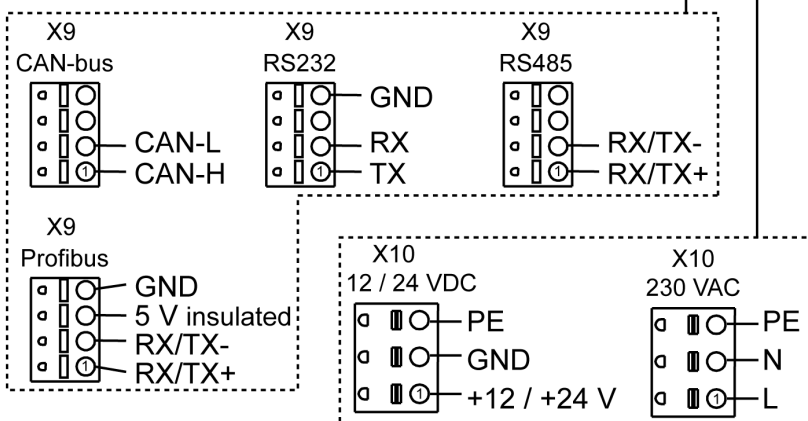
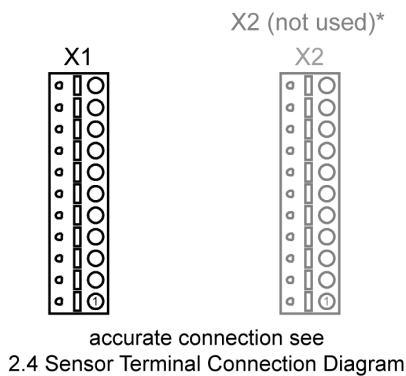

⚡ To avoid incorrect measurements, the PE contact of the power supply (slot X10) must be connected.

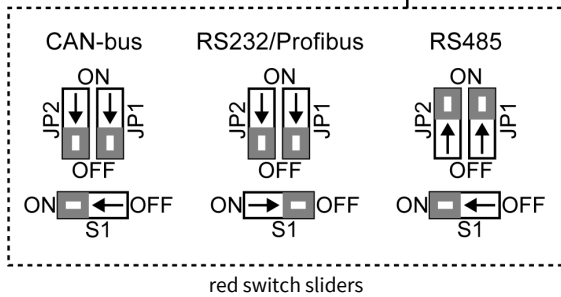

CAN-bus and RS485:
S1 at ON ⇒ terminated
S1 at OFF ⇒ not terminated

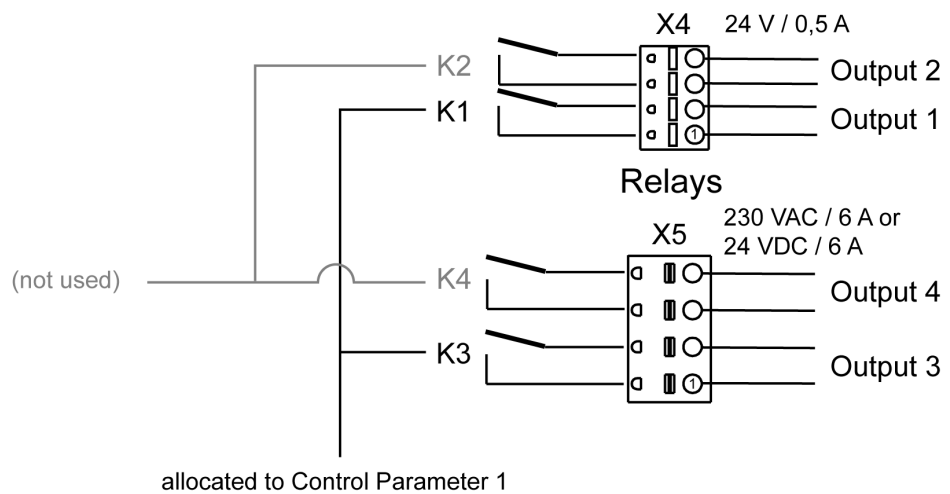

2.3 Connection Diagram 2 Control Parameter

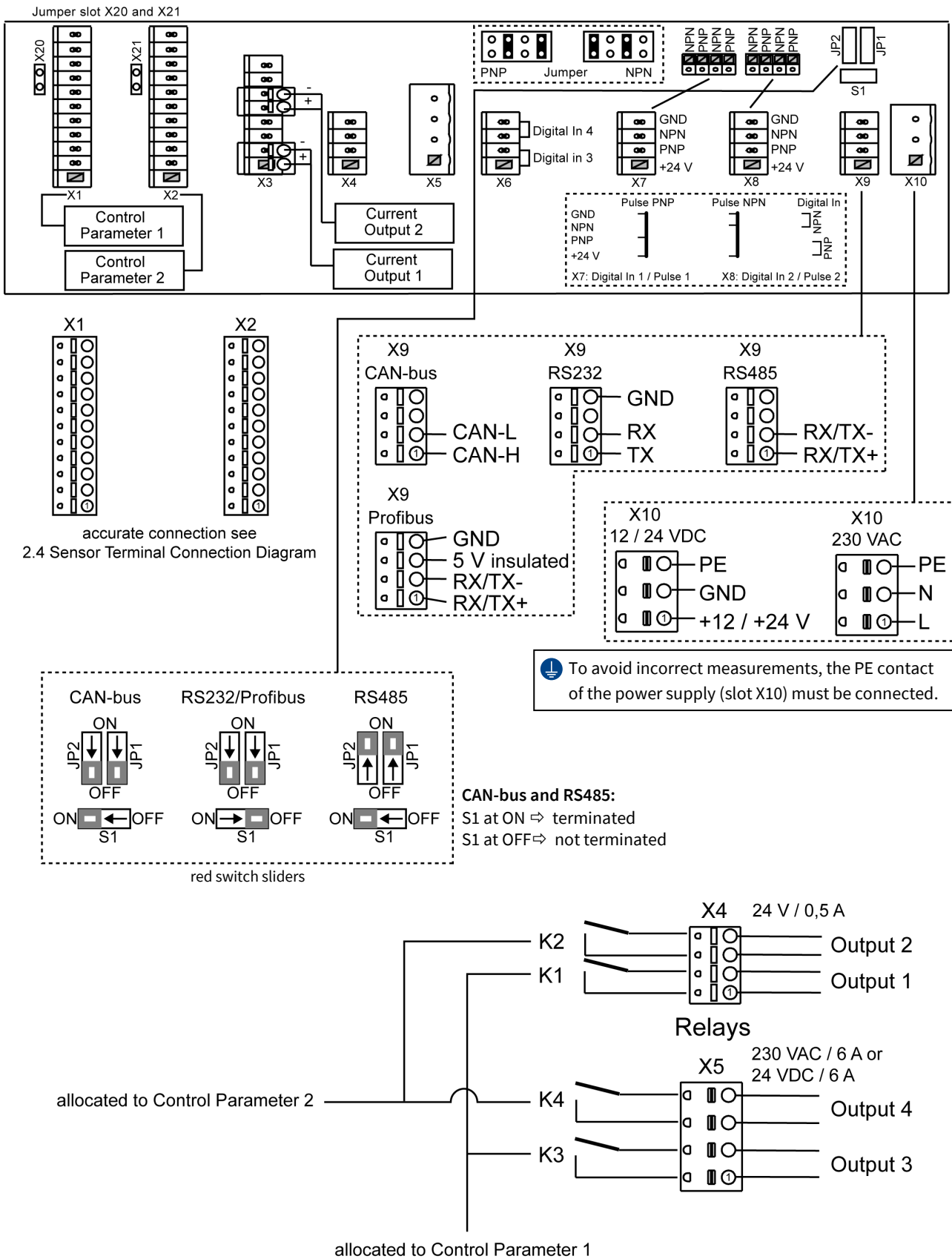

2.4 Sensor Terminal Connection Diagram

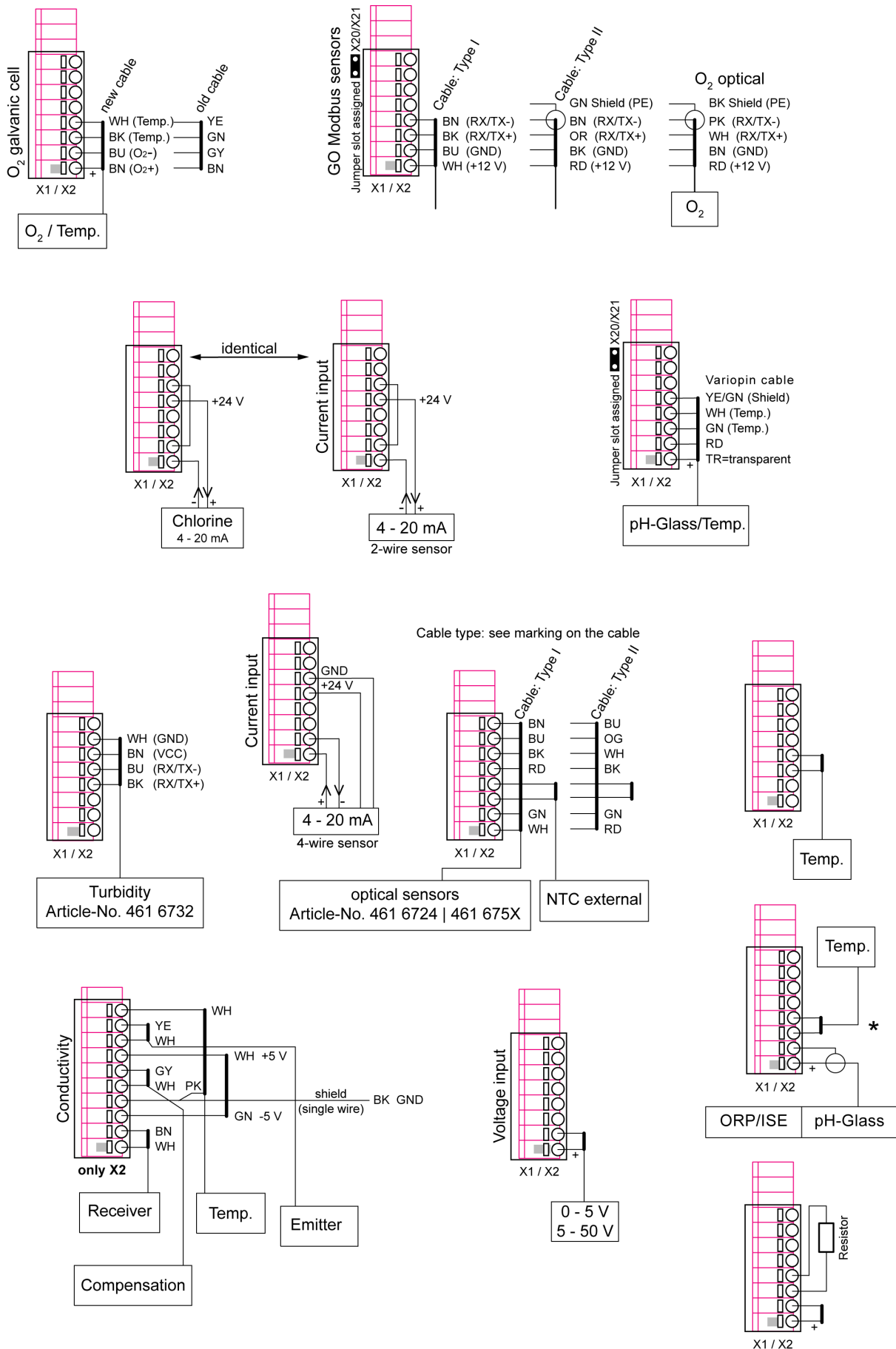

* If no temperature sensor is connected here, the open input must be closed with a resistor: |ORP/ISE approx. 27 kΩ| |pH-Glass approx. 1.2 kΩ|

2.5 Notes on the Pulse/Digital Inputs

The BlueSense Transducer has 4 galvanically isolated digital inputs.

Pulse Inputs 1 and 2:

The assignment of the pulse inputs 1 and 2 is set at connector X7 and X8.

The pulse inputs 1 and 2 are provided for the connection of PNP or NPN encoders:

- The selection between PNP and NPN is set at the associated jumper slots.
- Assignment see *2.2 Connection Diagram 1 Control Parameter*
or *2.3 Connection Diagram 2 Control Parameter*

The two pulse inputs 1 and 2 can also be used as static inputs:

- Selection PNP: Signal at connection of 24 V and PNP
- Selection NPN: Signal at connection of GND and NPN
- Assignment see *2.2 Connection Diagram 1 Control Parameter*
or *2.3 Connection Diagram 2 Control Parameter*

Digital Inputs 3 and 4:

The digital inputs 3 and 4 are static inputs.

The assignment of the digital inputs 3 and 4 is set at connector X6.

- Digital input 3: Signal at connection of the two lower clamp sockets
- Digital input 4: signal at connecting the two upper clamping sockets
- Assignment see *2.2 Connection Diagram 1 Control Parameter*
or *2.3 Connection Diagram 2 Control Parameter*

At static use all 4 digital inputs are closers (NO = normally open).

3 Hazard Note



Danger: Improper handling of electrical devices endangers man and property. Let carry out the commissioning of the BlueSense Transducer only by skilful, trained personnel using appropriate tools. Incorrect installation could cause serious faults and errors that may damage the device.

4 Turning On the System

After the Transducer is switched on a software check and system initialisation occurs.



When the system is operational, the parameter display is activated.

4.1 Parameter Display and Main Menu

4.1.1 Parameter Display

The parameter display can show up to 6 different values.

Here, as an example, the measured parameter display with 6 displayed values.

- **1 Oxygen:** the first control parameter oxygen
- **2 Temperature:** the associated temperature parameter for the first control parameter
- **3 Conductivity:** the second control parameter conductivity
- **4 Temperature:** the associated temperature parameter for the second control parameter
- **5 Salinity:** computed value from a conductivity measurement
- **6 Pulse 1:** value of the first pulse input

The names of the sensors are automatically numbered and listed.

In top left-hand corner the time is displayed. In top right-hand corner the date is displayed.

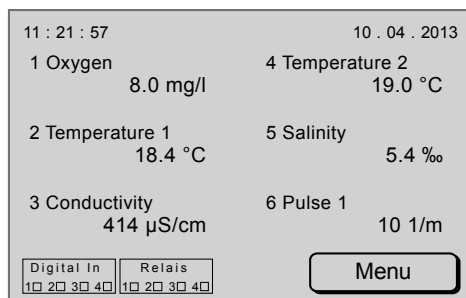

In the lower left corner the states of the 4 Digital In inputs and the switching states of the 4 relays are displayed (see Sensor terminal connection diagram).

A filled square (■) symbolizes the state 1, i.e. an input/relay is closed.

An empty square (□) symbolizes the state 0, i.e. an input/relay is open.

Status messages appear at the bottom of the parameter display (see Appendix E – Status and Error Messages).

When there is user inactivity in all other menus, the software switches in 2 minutes back to the Parameter Display. Not valid for input menus.

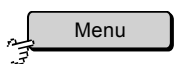

Switches to the Main Menu or, when the password protection is active, to a password prompt. see 4.1.1.1 Password Prompt and 4.1.2 Main Menu

4.1.1.1 Menu Password Prompt

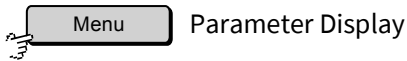

If the password protection is active, you have to enter a password here.
You activate and deactivate the password protection on the Main Menu, see next page.

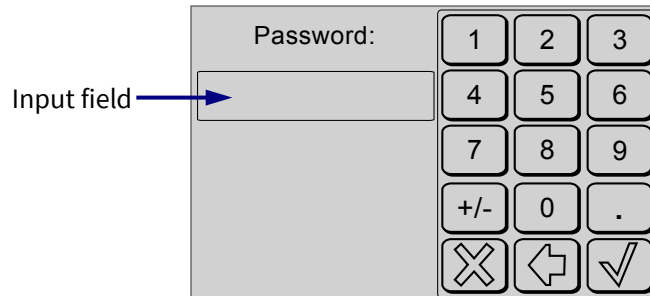



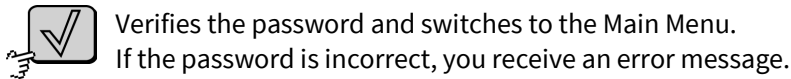
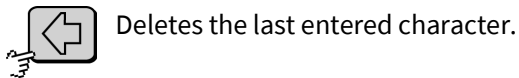
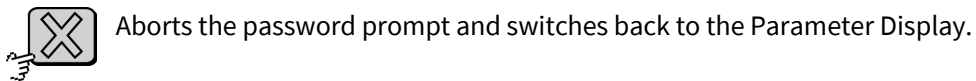
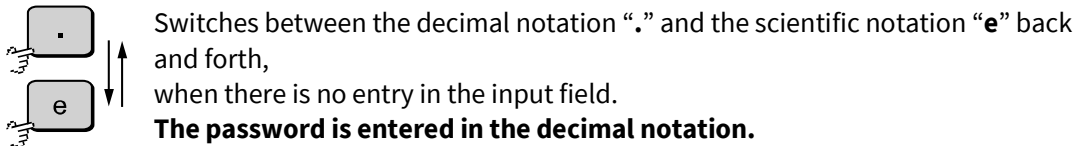



The necessary service password can be found in the enclosed Device Setup Sheet.

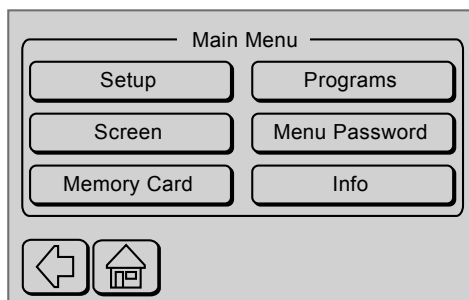

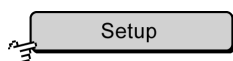
4.1.2 Main Menu

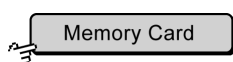
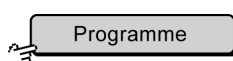
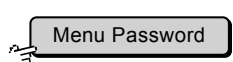
 Parameter Display

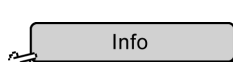

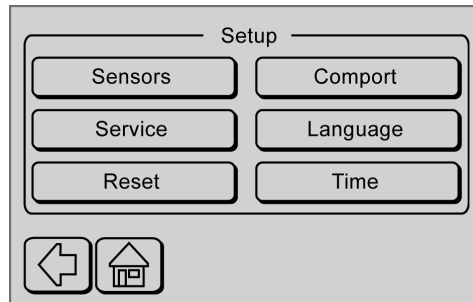

-  Switches to the Setup menu, see 5 *Setup*.
-  Switches to the setting of the Display illumination, see 6 *Screen*.
-  Switches to the Memory Card menu, see 7 *Memory Card*.
-  Switches to the Program menu, see 8 *Programs*.
-  Switches the password protection of the menus active or inactive. The button is also a status indicator.
-  Switches the password protection of the menus active or inactive. The button is also a status indicator.
-  Switches to the Info display of the transducer, see 9 *Info Transducer*.
-  Switches back to the Parameter Display.
-  Switches back to the Parameter Display.

5 Setup





From this menu you can adjust the settings of the connected sensors and change system parameters.

 **Sensors** Switches to the sensor menu, see *5.1 Sensors*.



 **Service** Switches to the password protected factory-presets. User changes are not necessary.



 **Reset** Switches to the Reset menu, see *5.2 Reset*.

 **Comport** Switches to the Comport menu, see *5.3 Comport*.

 **Language** Switches to language setting menu, see *5.4 Language Setting*.

 **Time** Switches to the time and date entry menu, see *5.5 Time/Date*.

  Switches back to the Main Menu.

  Switches to the Parameter Display.

5.1 Sensors

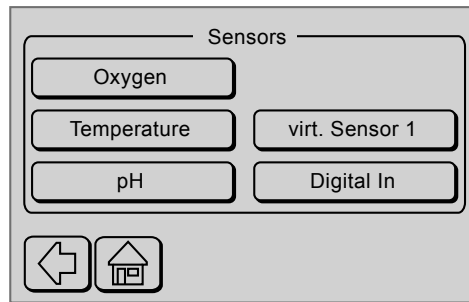
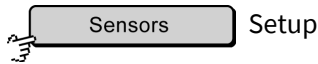

From this menu you can set the parameters of the connected sensors. The specific parameter setup is described in the sensor description.





The number of sensors that can be connected is determined by the delivered Transducer configuration. There are two configurations:

- **1 Control parameter**
One (1) sensor is connected. One control parameter is measured and where applicable the temperature as an associated parameter.
- **2 Control parameters**
Two (2) sensors are connected. Two control parameters are measured and where applicable the temperature for each sensor as associated parameters.

To determine if your transducer has one (1) or two (2) control parameters please refer to your shipping receipt.

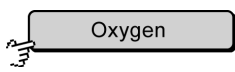
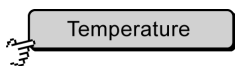
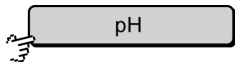
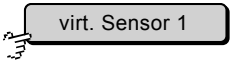
This example has:

- 1. Sensor: Oxygen sensor (first control parameter)
- 2. Sensor: Oxygen sensor's integrated Temperature sensor (associated parameter)
- 3. Sensor: pH sensor (second control parameter)
- 4. Sensor: Virtual sensor 1, which can calculate the salinity* from a conductivity measurement

-  Switches to the Sensor Setup of the first sensor, in this case oxygen, see 5.1.1 *Oxygen Sensor Setup (Control Parameter)*.
-  Switches to menu of the second sensor, in this case temperature, see 5.1.2 *Temperature Sensor Setup (Associated Parameter)*.
-  Switches to the menu of the third sensor, in this case pH.
-  Switches to the menu of the virtual Sensor. Settings as the temperature sensor
-  Switches to the information about the state of the digital inputs, see 5.1.3 *Digital In*.
-  Switches back to the Setup menu.
-  Switches to the Parameter Display.

* Salinity according to the general formula of the UNESCO for seawater

5.1.1 Oxygen Sensor Setup (Control Parameter)

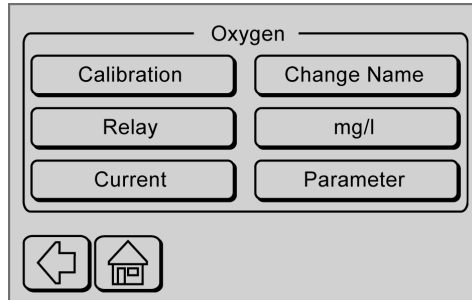
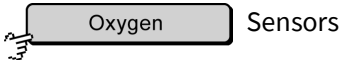

From this menu you can set the parameters of the selected sensor. The specific parameter setup is described in the sensor description.

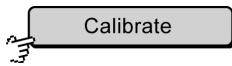

Switches to the Calibration menu for the sensor, see 5.1.1.1 Sensor Calibration.

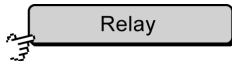

Switches to the Relay setup for the sensor, see 5.1.1.2 Relay Setup.

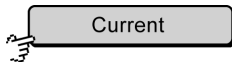

Switches to the Current Output setup for the first sensor, see 5.1.1.3 Current Output Setup.

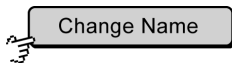

Switches to the renaming of the sensor, see 5.1.1.4 Change Name.

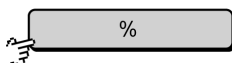
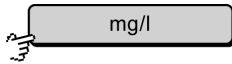

Switches between the units mg/l and %-saturation. The button is also a status indicator. Appears only if two measurement units are possible.

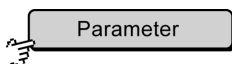

Switches to

- the setting of the estimated minimum and maximum measurement value of the sensor, needed for a connected BlueBox
- the setting of the number of single measurements from which the measurement value will be calculated by means of arithmetic averaging
- to the setting of the measurement interval

see 5.1.1.5 Parameter



Switches back to the Sensors menu.



Switches to the Parameter Display.

5.1.1.1 Sensor Calibration



Depending on the connected sensor there is a 1-point calibration or a 2-point calibration offered.*

! **Note:** With connected GO Modbus Sensors, this calibration on the BlueSense transmitter only causes a fine adjustment. The actual calibration is done with the calibration program of the GO Modbus Sensors. For more information see the specific documentation of the sensor or contact GO Systemelektronik.

5.1.1.1.1 Example One-Point-Calibration

Example Oxygen in mg/l:

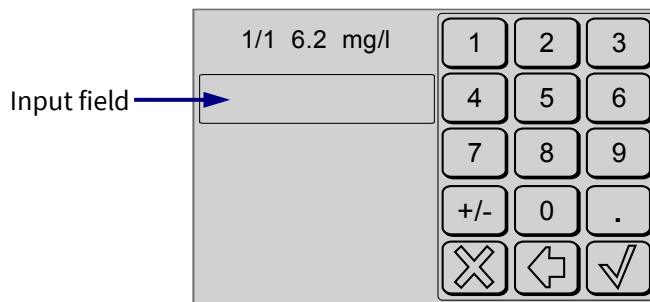

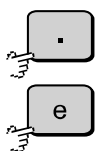

- 1/1** actual number of the measurement point / number of measurement points
- 6.2** actual measured value
- mg/l** unit of the measurement

Hold the sensor in a reference medium with a known value. This value has to be entered into the input field.

 Switches between the decimal notation “.” and the scientific notation “e” back and forth, when there is no entry in the input field.

 Aborts the password prompt and switches back to the Sensor Setup.

 Deletes the last entered character.

 Takes the value and switches back to the Sensor Setup. **Without an input the value is set to 0. Not recommended!**

The calibration is saved and completed.

* Exceptions possible, see *Appendix F – Multipoint Calibration*

5.1.1.1.2 Example Two-Point-Calibration

Example ORP:

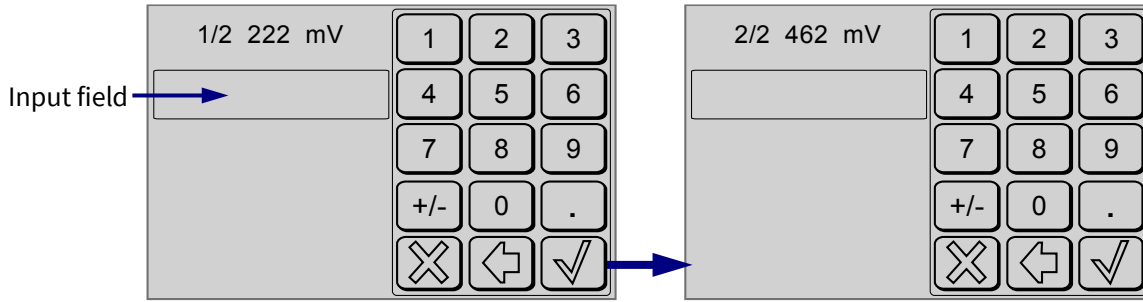

1/1 actual number of the measurement point / number of measurement points

2/2

222 actual measured values

462

mg/l unit of the measurement

Hold the sensor in reference fluid with known values. These values have to be entered into the input fields.

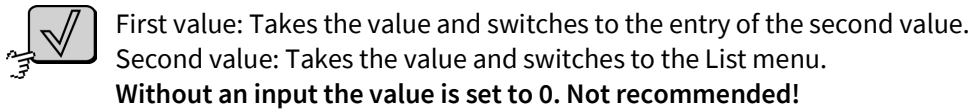
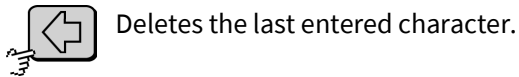
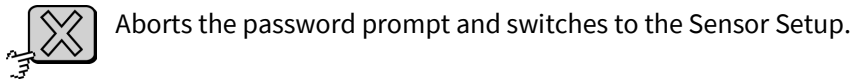
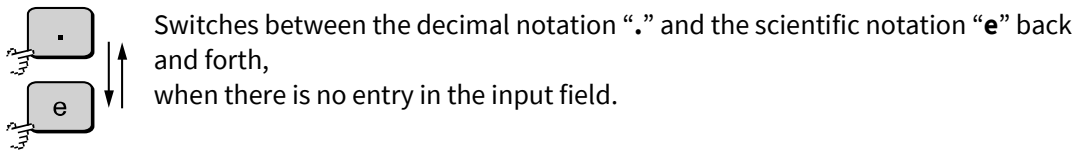

Number	Reference value	Input
1.	2.220000E+02	2.200000E+02
2.	4.620000E+02	4.680000E+02

List menu

List of Reference values and allocated Input values

With the List menu you can check the calibration values.

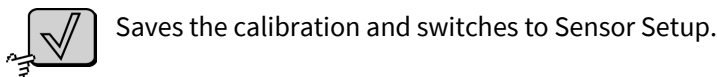
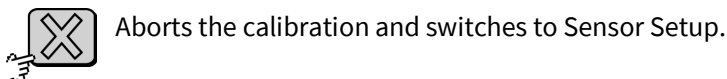

The calibration is saved and completed.

5.1.1.2 Relay Setup



Use these menus to set the four switching points of the associated relays* of the respective control parameters. The four switching points are determined by the minimum (sensor) value, the maximum (sensor) value and the value of the hysteresis.

1/3 Minimum

1	2	3
4	5	6
7	8	9
+/-	0	.
✕	←	✓

old value 2.00

1/3 Minimum value Input lower switching value

2/3 Maximum

1	2	3
4	5	6
7	8	9
+/-	0	.
✕	←	✓

old value 10.00

2/3 Maximum value Input lower switching value

3/3 Hysteresis

1	2	3
4	5	6
7	8	9
+/-	0	.
✕	←	✓

old value 1.00

3/3 Hysteresis Input hysteresis value

Number	Reference value	Input
1.	Minimum	4.00
2.	Maximum	8.00
3.	Hysteresis	1.00

✕ ✓

 Aborts the input and switches to Sensor Setup.

 Aborts the input and switches to Sensor Setup.

 Deletes the last entered character.

 Saves the settings and switches to Sensor Setup.

 Saves the input and switches to the next menu. Without setting the old value is stored.

The setting of the relay is saved and completed.

Example:

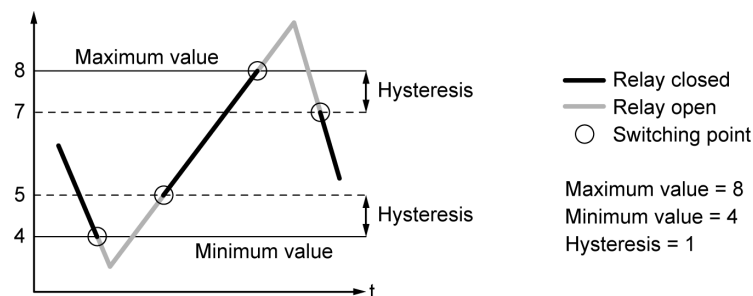

* 1. control parameter ⇒ Relay K1|K3 2. control parameter ⇒ Relay K2|K4
 see 2.2 Connection Diagram 1 Control Parameter or 2.3 Connection Diagram 2 Control Parameter

5.1.1.3 Current Output Setup

 **Current** Sensor Setup (control parameter)

 **Precondition:** The transducer must be in the "regulation intern" status.
see 8 Programs

The Sensor signal controls the allocated current output (control parameter 1 ⇒ current output 1, control parameter 2 ⇒ current output 2).

Thus, the signal is accurately represented by the current output, you must set a **measurement range**.

Use these menus to determine the measurement range with the input of a minimum and a maximum value.

Example:

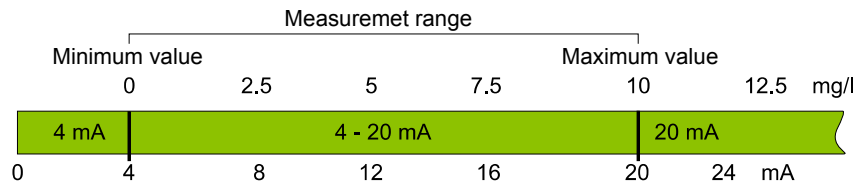

1/2 4 mA

1	2	3
4	5	6
7	8	9
+/-	0	.

old value
0.00

1/2 4 mA

Input of the measurement value that corresponds to 4 mA.

Minimum value of the measurement range

2/2 20 mA

1	2	3
4	5	6
7	8	9
+/-	0	.

old value
10.00

2/2 20 mA

Input of the measurement value that corresponds to 20 mA.

Maximum value of the measurement range

Existing settings are displayed as "old value".

Number	Reference value	Input
1.	4 mA	0.00
2.	20 mA	10.00

 Aborts the input and switches to the Sensor Setup.

 Aborts the settings and switches to the Sensor Setup.

 Deletes the last entered character.

 Saves the settings and switches to the Sensor Setup.

 Saves the input and switches to the next menu.
Without setting the old value is stored.

The current settings are saved and completed.

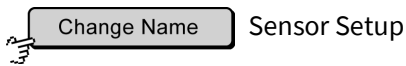

5.1.1.4 Change Name

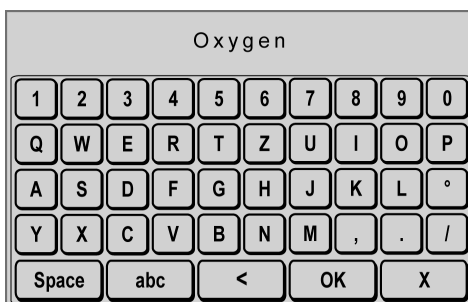

Example Oxygen:



From this menu you can set the name of the connected sensor.

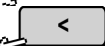
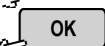
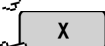



-  Space character
-  Capitalization.
-  Deletes the last entered character.
-  Save the input and switches back to the Sensor parameter setup.
-  Switches back to the Sensor parameter setup without saving the input.

5.1.1.5 Parameter

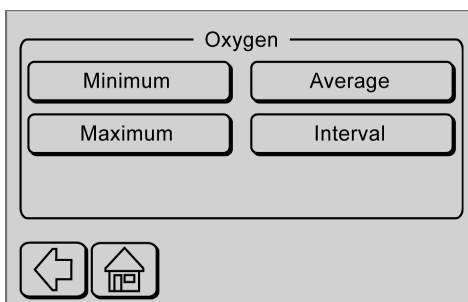

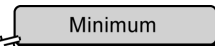
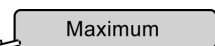
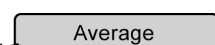
Example Oxygen:



-  Switches to the input of the expected minimum measurement value of the sensor for a BlueBox connected to the transducer.
-  Switches to the input of the expected maximum measurement value of the sensor for a BlueBox connected to the transducer.
-  Switches to the input of the number of single measurements from which the measured value is arithmetically averaged.
-  Switches to the setting of the measurement interval.
-  Switches back to Sensor Setup.
-  Switches to the Parameter Display.

5.1.1.5.1 Minimum Value and Maximum Value

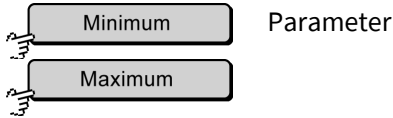

Input of minimum and maximum sensor measured values

! **Note:** If the value falls below/exceeds, the entered minimum value or the entered maximum value is **displayed and saved**.

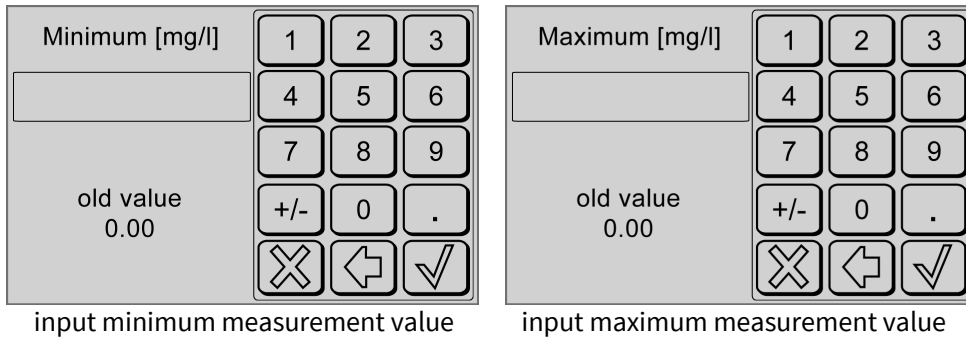

The presently active value is displayed as “old value“.

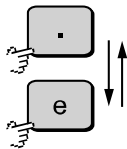

Switches between the decimal notation “.” and the scientific notation “e” back and forth, when there is no entry in the input field.



Aborts the password prompt and switches back to the Parameter menu.

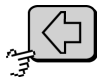

Deletes the last entered character.



Saves the input and switches back to the Parameter menu. Without setting the old value is stored.

5.1.1.5.2 Average and Interval

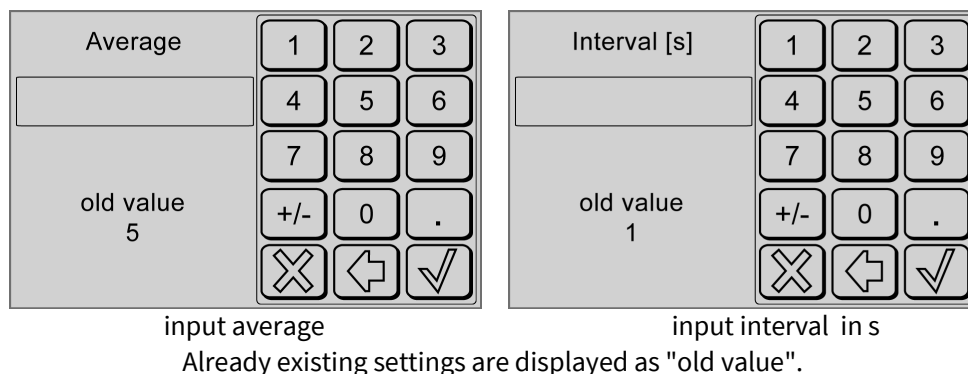

Average:

The measurement value is the arithmetic average of the last here entered number of single measurements (default setting is here 5).*

Interval:

Time in seconds between the start of a single measurement and the start of the next single measurement (default setting is here 1 s).

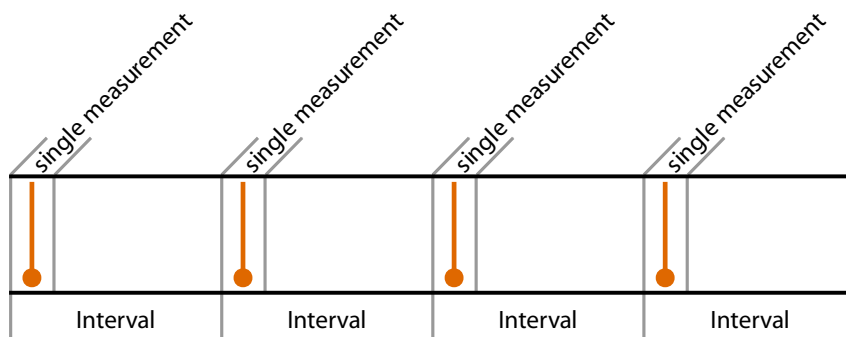

Example: measurement from 4 single measurements

The average and interval values vary depending upon the connected sensor.



Switches back to the Parameter menu without saving the input.



Deletes the last entered character.



Saves the input and switches back to the Parameter menu. Without setting the old value is stored.

* This is therefore the moving average value. If not enough single measurements are available (i.e. after a restart or a setting chance), no measured value is generated.

5.1.2 Temperature Sensor Setup (Associated Parameter)

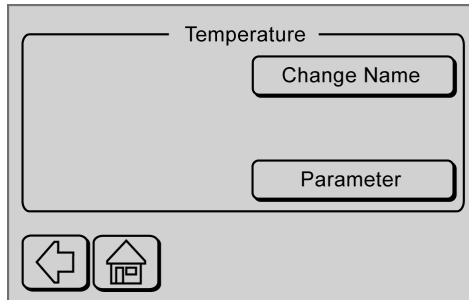
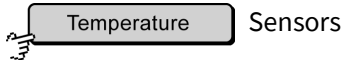

In setting up the associated parameter Temperature, only the name of the sensor can be changed.

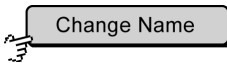

Switches to the renaming of the temperature sensor, see 5.1.1.4 Change Name.

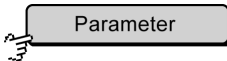

Switches to

- the defining of the measurement value range of the sensor
 - the setting of the number of single measurements from which the measurement value will be calculated by means of arithmetic averaging
 - to the setting of the measurement interval
- see 5.1.1.5 Parameter.



Switches back to the Sensors menu.



Switches to the Parameter Display.

5.1.3 Digital In

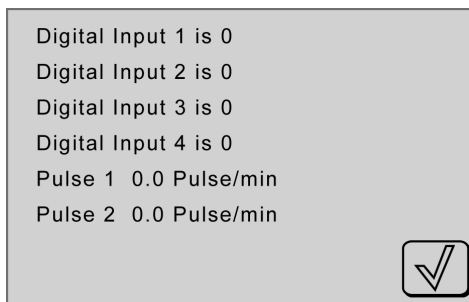

Here the state of the digital inputs is displayed. If no sensor is connected, either 0 or 0.0 is displayed. see 2.5 Notes on the Pulse/Digital Inputs



Switches back to the Sensors menu

5.2 Reset

 Setup menu

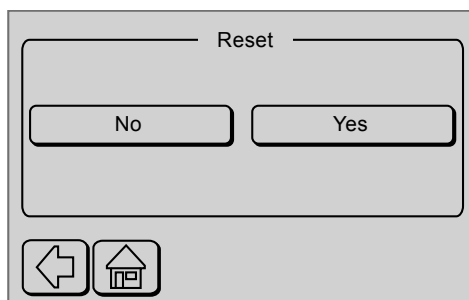

 Switches back to the Setup menu.

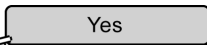
 Resets all user settings to factory settings.
Exception: Sensor calibration data remains unchanged.
 Switches back to the display of Measured Values.

 Switches back to the Setup menu.

 Switches to the Parameter Display.

5.3 Comport

Settings for the RS232/RS485 interface and for CAN-bus.

 Setup menu.

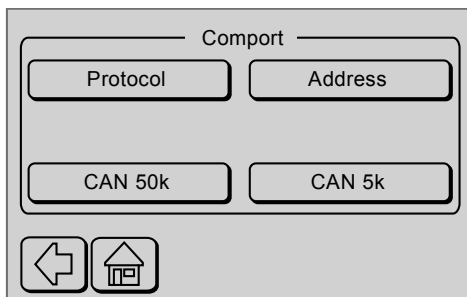

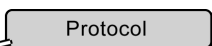

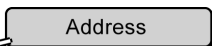
 Switches to the Activation/Inactivation of the Modbus protocol.
Only visible if a RS232/RS485 interface is existing.

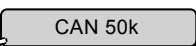
 Switches to the input of the Modbus address of the transducer,
see 5.3.2 *Modbus Address Input*.
Only visible if a RS232/RS485 interface is existing.

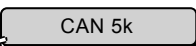
 Sets the CAN-bus data transfer rate to 50 kbit/s.
The button is also a status indicator.
Only visible if a CAN-bus interface is existing.

 Sets the CAN-bus data transfer rate to 5 kbit/s.
The button is also a status indicator.
Only visible if a CAN-bus interface is existing.

 Switches back to the Setup menu.

 Switches to the Parameter Display.

5.3.1 Protocol Selection

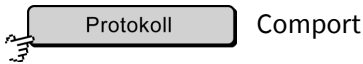

This menu is designated for the selection between different transmission protocols in future firmware versions.

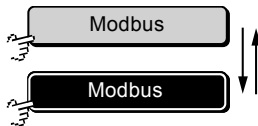
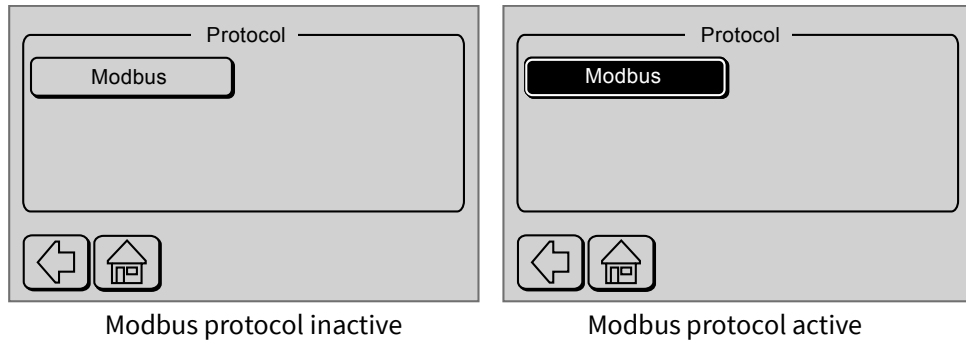

Switches the Modbus protocol active or inactive. The button is also a status indicator.



Switches back to the Comport menu.



Switches to the Parameter Display.

Note: The RS232 and RS485 interfaces can be operated only useful with active Modbus protocol.

5.3.2 Modbus Address Input

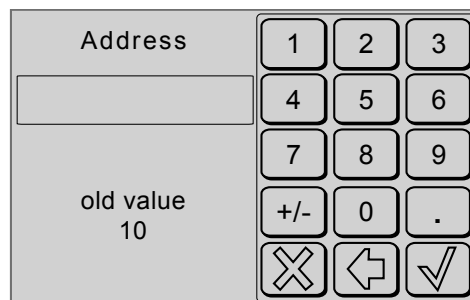
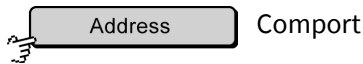

Here you can enter the Modbus address of the transducer for the RS232 or RS485 interface, the factory setting is 10.

The presently active value is shown as "old value".



Switches back to the Comport menu without saving the input.



Deletes the last entered character.



Saves the input and switches back to the Comport menu. Without setting the old value is stored.

5.4 Language Setting

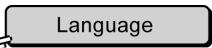
 Setup

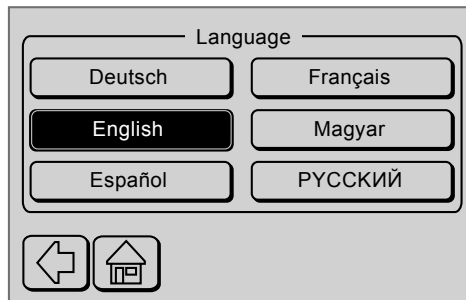

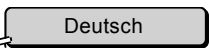

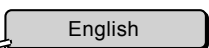
 Sets the menu language to German. The button is also a status indicator.

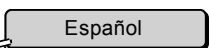
 Sets the menu language to English. The button is also a status indicator.

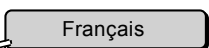
 Sets the menu language to Spanish. The button is also a status indicator.

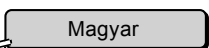
 Sets the menu language to French. The button is also a status indicator.

 Sets the menu language to Hungarian. The button is also a status indicator.

 Sets the menu language to Russian. The button is also a status indicator.

 Switches back to the Setup menu.

 Switches to the Parameter Display.

5.5 Time/Date

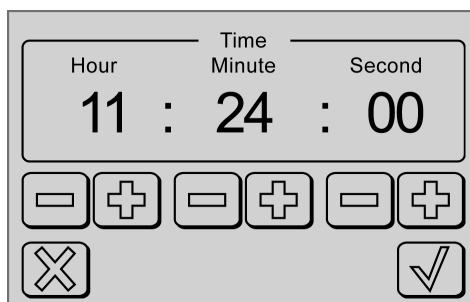
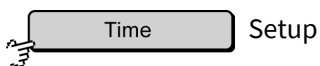

Time input



Reduces the hours / minutes / seconds by 1



Increases the hours / minutes / seconds by 1



Switches back to the Setup menu without storing the entry.



Saves the entry and switches to the date input.

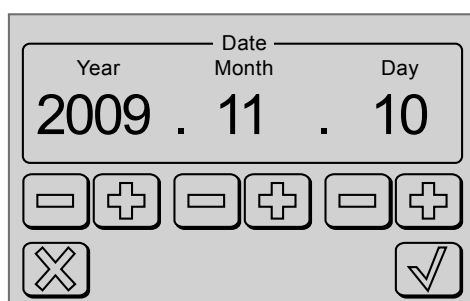

Date input



Reduces the year / month / date by 1



Increases the year / month / date by 1



Switches back to the Setup menu without storing the entry.



Saves the entry and switches back to the Setup menu.

6 Screen

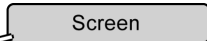
 Main Menu

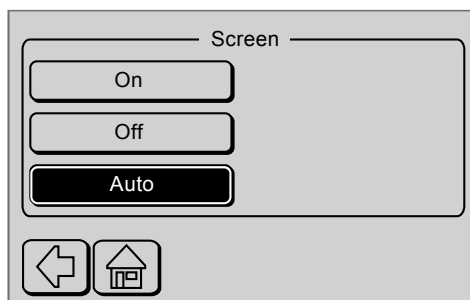

 On

Turns on the backlight of the display.
The button is also a status indicator.

 Off

Turns off the backlight of the display.
The button is also a status indicator.

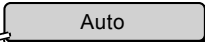
 Auto

Turns off the backlight of the display after 60 s user inactivity.
Does not apply to input menus.
Pressing any button switches the backlight on again.
The button is also a status indicator.

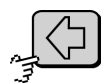

Switches back to the Main Menu.



Switches to the parameter display.

7 Memory Card

7.1 Save Data

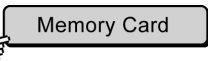
 Main Menu

The data collected by the transducer are continuously stored in a csv-file on an SD Memory Card. This csv-file will be opened with a suitable program on a PC (see 7.4 Read Data).

When the SD Memory Card is full, error message 50 appears (see Appendix E – Status and Error Messages there 2 Error messages).

 The SD Memory Card must be formatted with **FAT16**. NOT: FAT16(LBA) or FAT32 or NTFS!

 In Windows 10, FAT16 has been replaced by FAT16(LBA).

FAT16 formatting can be performed with the *SD Memory Card Formatter 5.0* program, for example.
 Weblink: www.sdcard.org/downloads/index.html

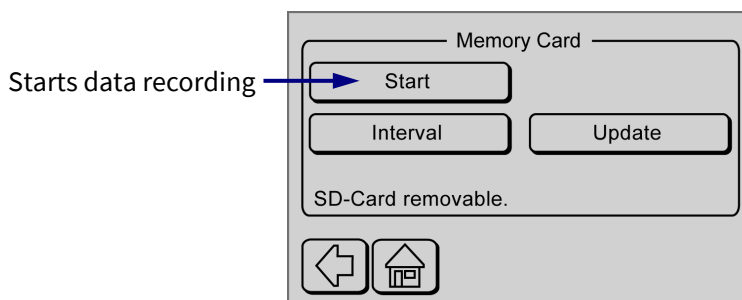
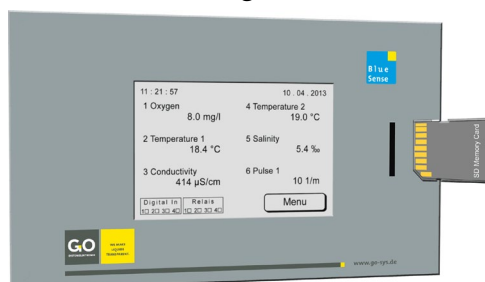

After inserting the SD Memory Card press <Start>. The SD Memory Card is detected as long as “Please wait ...” appears on the display.

Thereafter the following menu appears, and the SD Memory Card is written.

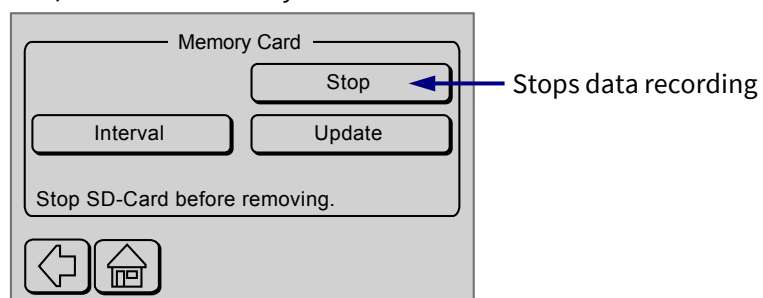

If the transducer starts with an inserted SD Memory Card (e.g. after a power failure), the data recording starts automatically.

 The SD Memory Card may only be removed after you have pressed <Stop>. Otherwise the data on the SD Card is corrupted.

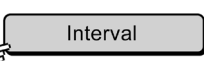
 Switches to the input of the storage interval.

 Switches back to the Main Menu.

 Switches to the firmware update.

 Switches to the Parameter Display.

7.2 Adjustment of the Storage Interval

 Memory Card

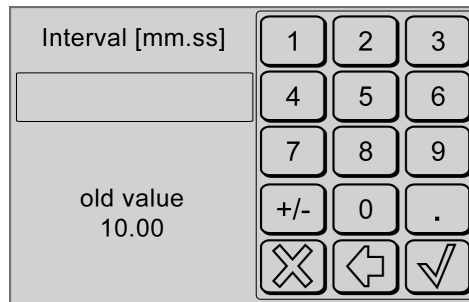



Input format mm.ss

minimum input = 00.05 (5 s) maximum input = 60.00 (60 m)
The presently active value is displayed as “old value“.

From this menu you can set the storage interval in minutes.

 Switches back to the Memory Card menu without saving the input.

 Deletes the last entered character.

 Saves the input and switches back to the Memory Card menu. Without setting the old value is stored.

7.3 Update (Firmware)

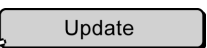
 Main Menu

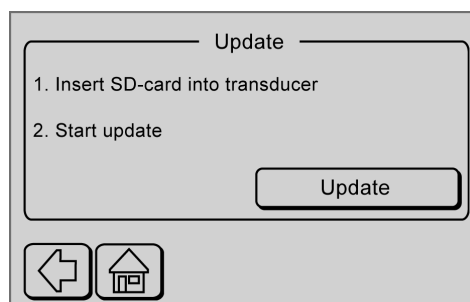

The SD Memory Card with the BlueSense Transducer firmware you receive from GO Systemelektronik.

 Starts the Firmware-Update. Follow the instructions.

 Switches back to the Main Menu.

 Switches to the Parameter Display.

7.4 Read Data

The transducer stores the states of the inputs (and therefore also the measured values) and the error messages as a csv-file. In this file the individual values are separated with a **semicolon***. It is recommended to open these files with a program that displays the data in a clearly arranged way.

Example: opening a csv-file with the program Calc from the OpenOffice package.

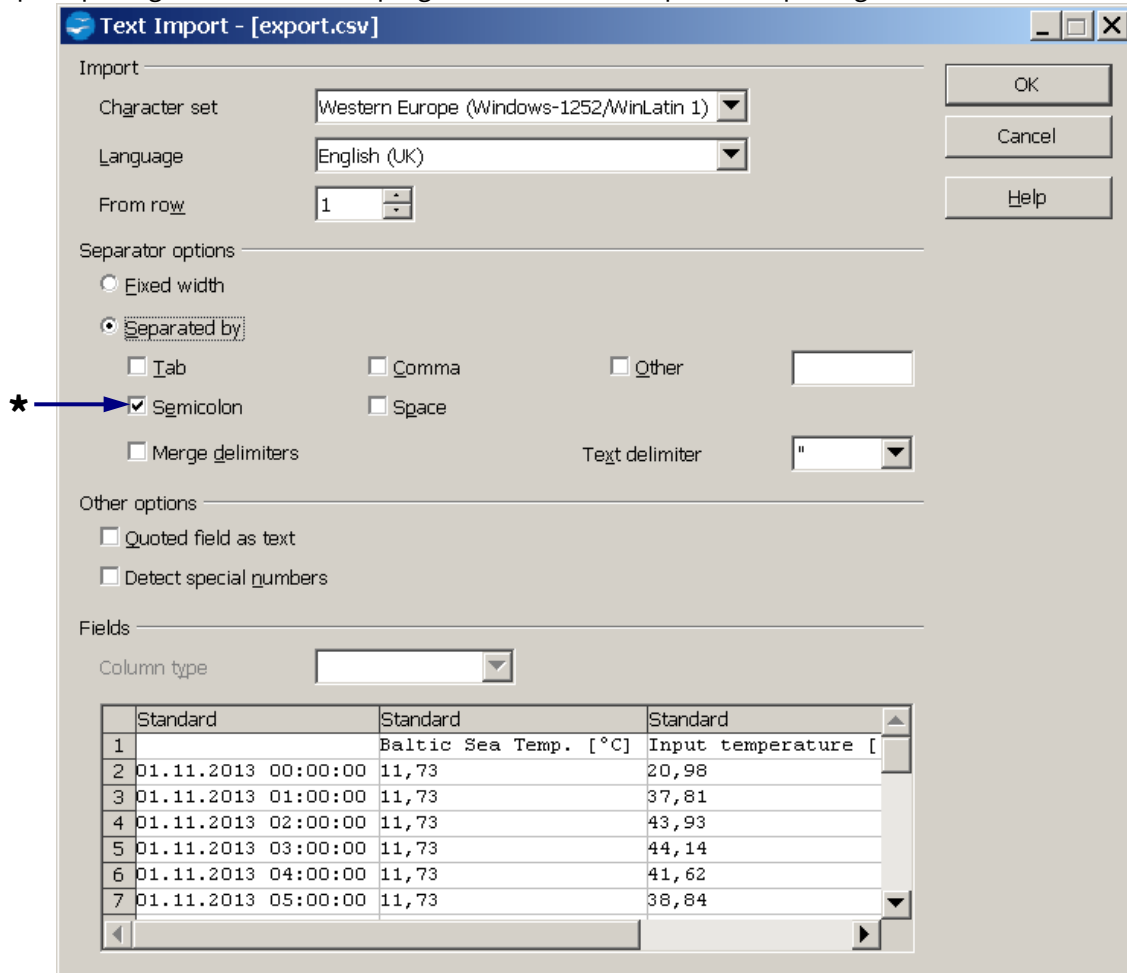

Note: If you selected English as the menu language of the BlueSense Transducer, the decimal separator is a dot.

Note: Columns with entries with leading zeros (for example on digital inputs) must be converted when opened in the text format. Otherwise, leading zeros are ignored.

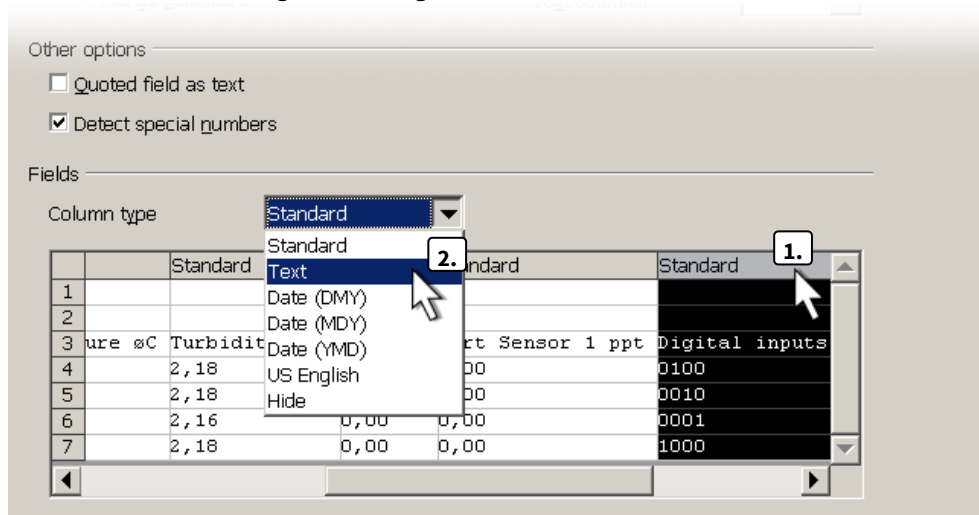

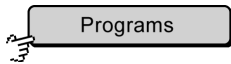

8 Programs

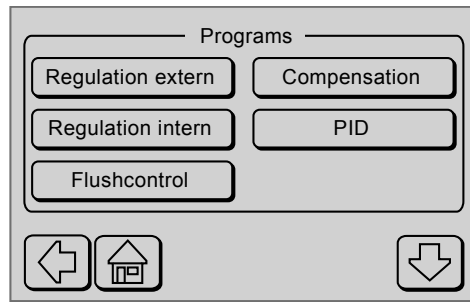
 Main Menu



 Switches to the Main Menu.

 Switches to the Parameter Display.

 here without function

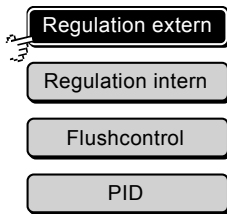

In the status “**regulation extern**” the current outputs and the relays are controlled by the remote station via the communication protocol.

The button is also a status indicator.

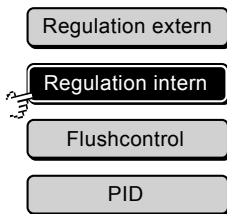

In the status „**regulation intern**” the current outputs and the relays are controlled by the transducer via the measurement values.

The button is also a status indicator.

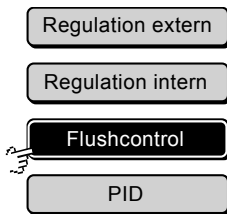

In the status „**Flushcontrol**“ :

- The relays are controlled from the internal flush parameters (see parameters).
- The current outputs of the transducer are controlled via the measurement values.

The button is also a status indicator.

Pressing this button starts the flushing (see 8.1).

After activating the flushcontrol, the measured values of the next ca. 60 seconds will not be saved on the SD card.

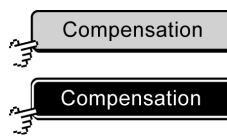

Switches the compensation of a chlorine measurement with pH-value and temperature on and off. The button is also a status indicator.

Precondition: chlorine measuring board and pH measuring board with integrated temperature measuring. If this precondition is not fulfilled, this function is without effect.



During the calibration of the chlorine sensor the compensation must be **switched off**.

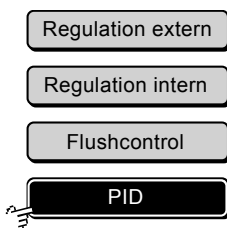

In the status „**PID**” the current outputs and the relays are controlled by the PID controller (Proportional–Integral–Derivative).*

The button is also a status indicator.

Pressing the activated button switches to the PID control parameters (see 8.2).

* Is only effective if the PID controller is activated in the parameterization (see 8.2).

8.1 Flushcontrol Parameters



Setting of Flushtime, Interval and Relaxtime

The **Flushtime** is the duration of flushing, i.e. the time for which relays K1 and K3 close. In the flushtime no new measurement will be acted upon.

The **Interval** is the time between the beginning of a flush and the beginning of the next flush. If flushtime + latencytime is greater than the interval, then the next flush will occur 1 min after the relaxtime.

The **Relaxtime** is the time after the end of the flushtime in which the sensor can adjust to the surrounding medium. In this time no new measurement will be acted upon.

1/3 Flushtime [s]

1	2	3
4	5	6
7	8	9
+/-	0	.
✕	←	✓

old value
10

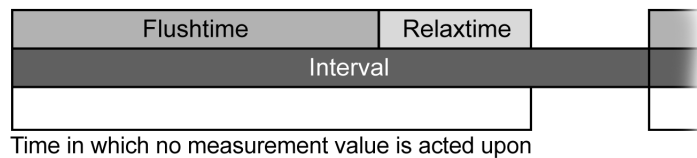

2/3 Interval [m]

1	2	3
4	5	6
7	8	9
+/-	0	.
✕	←	✓

old value
30

Presently active values are shown as "old value".

3/3 Relaxtime [m]

1	2	3
4	5	6
7	8	9
+/-	0	.
✕	←	✓

old value
1

Number	Referencevalue	Input
1.	Flushtime [s]	10
2.	Interval [m]	30
3.	Relaxtime [m]	1

✕ ✓

 Aborts the setting and switches to the Programs Menu.

 Aborts the input and switches to the Programs Menu.

 Deletes the last entered character.

 Saves the settings and switches to the Programs Menu.

 Saves the input and switches to the next menu. Without setting the old value is stored.

The settings of the Flushcontrol are saved and completed.



8.2 Parameter PID





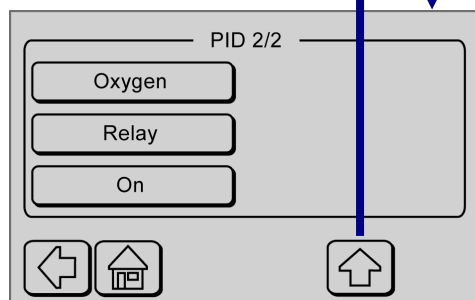
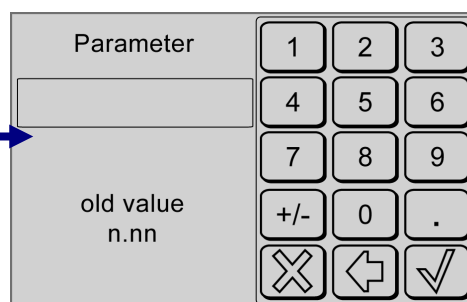
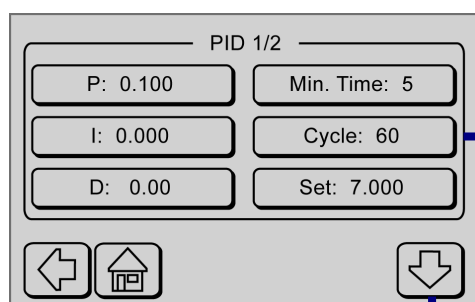
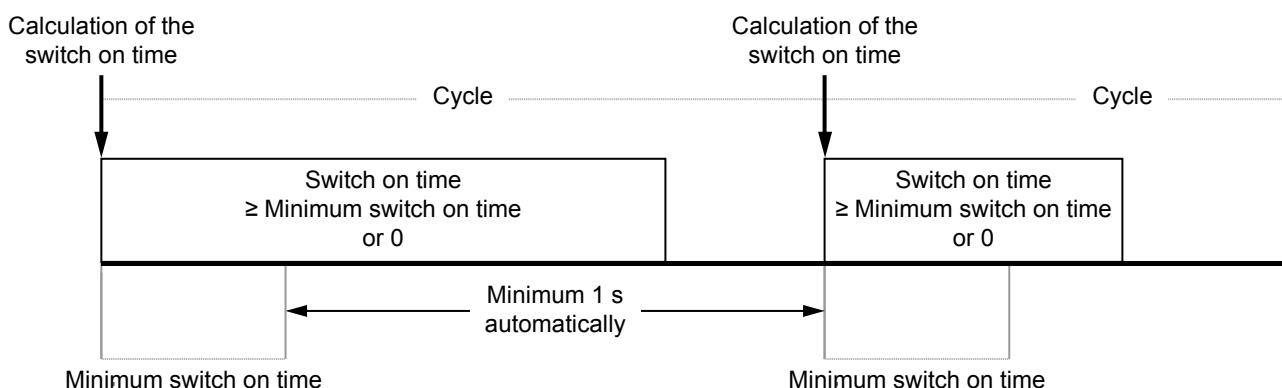











The PID controller has a proportional, an integral and a differential share of the control effect. The respective strength of the portion of the control action is determined by the input values for P, I and D.

Actual value is the measurement value of the associated sensor. **Desired value** is a value from the range of the associated sensor. **Actuating variable** is either a current of 4 mA - 20 mA (current output 1), or the difference between the on-and off the relay (contact parallel K1/K3).



-  Aborts the setting and switches to the Programs Menu.
-  Deletes the last entered character.
-  Saves the input and switches to the next menu. Without setting the old value is stored.

BlueSense

-  **P: 0.100** Switches to the input of the P-values.
Presently active values are shown as “old value“.
-  **I: 0.000** Switches to the input of the I-values.
Presently active values are shown as “old value“.
-  **D: 0.000** Switches to the input of the D-values.
Presently active values are shown as “old value“.
-  **Min. Time: 5** Switches to the input of the Minimum switch on time of the relay [s]. If the entered minimum time \geq cycle, the program sets cycle = minimum + 1.
Presently active values are shown as “old value“.
-  **Cycle: 60** Switches to the input of the control interval [s].
Presently active values are shown as “old value“.
-  **Set: 7.000** Switches to the input of the desired value. The input range is the measurement range of the associated sensor.
Presently active values are shown as “old value“.
-  Switches back to the Programs Menu.
-  Switches to the Parameter Display.
-  **Oxygen** Switches to the sensor selection of the PID control. The current sensor is displayed on the button.
-  **Relay** Switches between the actuators relay (contact parallel K1/K3) and power output (current output 1) back and forth, the button is also a status display.
-  **Current**
-  **Off** Deactivates and activates the PID control.
The button is also a status display.
-  **On**
- Here you can deactivate the PID control without activating any other program in the Programs menu (see 8)*.
- While the PID control is disabled,
- shows the PID button in the Program menu (see 8) still an active status,
 - no programs are running
-  Switches back to the Programs Menu.
-  Switches to the Parameter Display.

* e.g. for a sensor calibration

8.2.1 Parameter PID (Sensor selection)

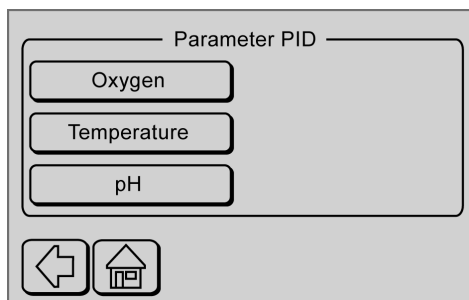

selection of the sensor of the PID control



Switches back to menu PID 1/2.



Switches to the Parameter Display.

9 Info Transducer

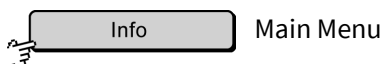

Displays the firmware version (here 3.03 | -7 -fc is a service note), the serial number* (S/N) of the transducer and the serial numbers of the sensor measuring boards (KV 0, KV 1,...)



Switches back to the Main Menu.



Switches to the Parameter Display.

* The serial number of the transducer is also the CAN-ID (in other contexts also called DAM-ID) of the transducer for a connected BlueBox (bls + 5 digits).

10 Installation Notes

The Transducer should only be installed by skilled or instructed persons with the suitable tools. In the case of incorrect assembly serious malfunctions and errors can occur which can destroy the device.

Before connecting the device to electricity it is important to check the power supply network connection data (voltage and frequency) of your utility provider. This data must correspond. If in doubt, ask your electrician.

Only pull the plug from the Transducer when it is off, never when it is on!

Only use the Transducer when the lid is closed, so that no electrical components can be touched.

The electrical safety of the device and optimal RFI protection are only guaranteed if the device is connected to a properly installed protective conductor system. In case of doubt, call a professional to check the installation. The manufacturer cannot be held responsible for any damage or malfunctions caused by a missing or broken ground wire.

During installation the device must not be connected to the power supply mains!

The connection of the device to mains power shall not be via extension cables because these do not guarantee the necessary protection.

11 Maintenance Instructions

The Transducer itself is maintenance free. The sensors, however, should be periodically cleaned and calibrated. The timeframes for cleaning and calibration depend heavily on the application.

Appendix A - Modbus

1. Introduction

The functionality of the Modbus protocol is limited to the following switches and registers. In future versions all settings will be able to be controlled via Modbus.

The registers are 32 bit.

2. Modbus Mapping Table

2.1 Discrete Output Coils (Read & Write) (MODBUS Register Table 00001 - 10000)

Number	Address	Description	Data format	Size
1	0x0000	Relay 1	Bit	1 Bit
2	0x0001	Relay 2	Bit	1 Bit
3	0x0002	Relay 3	Bit	1 Bit
4	0x0003	Relay 4	Bit	1 Bit
5	0x0004 to 0x0070	reserved for future functions	-N/A-	-N/A-

2.2 Discrete Input Coils (Read-Only) (MODBUS Register Table 10001 - 30000)

Number	Address	Description	Data format	Size
1	0x0000	Digital Input 1	Bit	1 Bit
2	0x0001	Digital Input 2	Bit	1 Bit
3	0x0002	Digital Input 3	Bit	1 Bit
4	0x0003	Digital Input 4	Bit	1 Bit
5	0x0004 - 0x0070			

2.3 Analogue Output Holding Registers (Read & Write) (MODBUS Register Table 40001+)

Number	Address	Description	Data format	Size
1	0x0000	analogue value of current output 1	32 bit float	2x16 bit Registers
2	0x0001	analogue value of current output 2	32 bit float	2x16 bit Registers
3	0x0002 to 0x000F	reserved for future functions	-N/A-	-N/A-
4	0x0010 to 0x0013	name of the first measurement value	16 Char String	8x16 bit Registers
5	0x0014 to 0x0017	name of the second measurement value	16 Char String	8x16 bit Registers
6	0x0018 to 0x001B	name of the third measurement value	16 Char String	8x16 bit Registers
7	0x001C to 0x001F	name of the fourth measurement value	16 Char String	8x16 bit Registers
8	0x0020 to 0x0023	name of the first pulse input	16 Char String	8x16 bit Registers
9	0x0024 to 0x0027	name of the second pulse input	16 Char String	8x16 bit Registers
10	0x0028 to 0x002B	name of the first current output	16 Char String	8x16 bit Registers
11	0x002C to 0x002F	name of the second current output	16 Char String	8x16 bit Registers
12	0x0030 to 0x0040	reserved for future functions	-N/A-	-N/A-

2.4 Analogue Input Register (Read Only) (MODBUS Register Table 30001 - 40000)

Number	Address	Description	Data format	Size
1	0x0000	first measurement value	32 bit float	2x16 bit Registers
2	0x0001	second measurement value	32 bit float	2x16 bit Registers
3	0x0002	third measurement value	32 bit float	2x16 bit Registers
4	0x0003	fourth measurement value	32 bit float	2x16 bit Registers
5	0x0004	first pulse input	32 bit float	2x16 bit Registers
6	0x0005	second pulse input	32 bit float	2x16 bit Registers
7	0x0006 to 0x000F	reserved for future functions	-N/A-	-N/A-
8	0x0010 to 0x0011	first unit of the first measurement value	8 Char String	4x16 bit Registers
9	0x0012 to 0x0013	second unit of the first measurement value	8 Char String	4x16 bit Registers
10	0x0014 to 0x0015	first unit of the second measurement value	8 Char String	4x16 bit Registers
11	0x0016 to 0x0017	second unit of the second measurement value	8 Char String	4x16 bit Registers
12	0x0018 to 0x0019	first unit of the third measurement value	8 Char String	4x16 bit Registers
13	0x001A to 0x001B	second unit of the third measurement value	8 Char String	4x16 bit Registers
14	0x001C to 0x001D	first unit of the fourth measurement value	8 Char String	4x16 bit Registers
15	0x001E to 0x001F	second unit of the fourth measurement value	8 Char String	4x16 bit Registers
16	0x0020 to 0x0040	reserved for future functions	-N/A-	-N/A-

2.5 Profibus Modbus Mapping

Profibus Slave Memory

Columns:	<input type="text" value="8"/>	Display mode	<input type="text" value="Hexadecimal"/>					
Input data								
Offset:	<input type="text" value="0000"/>	<input type="button" value="Go"/>						
	00	01	02	03	04	05	06	07
0000	84	8C	C8	40	00	00	A0	C0
0008	BF	41	AD	40	00	00	40	40
0010	00	00	00	00	00	00	00	00
0018	00	00	00	00	00	00	00	00

All values are 4 Byte FLOATING POINT.

		Address
1. Card	Value 1	0x00 – 0x03
	Value 2	0x04 – 0x07
2. Card	Value 1	0x08 – 0x0B
	Value 2	0x0C – 0x0F

Example:

0x40C88CB4	-	6,2672
0xC0A00000	-	-5
0x40AD41BF	-	5,6047
0x40400000	-	3

BlueSense - Connection BlueBox

Appendix B - Connection to a BlueBox

Precondition: The transducer has a CAN-bus interface.

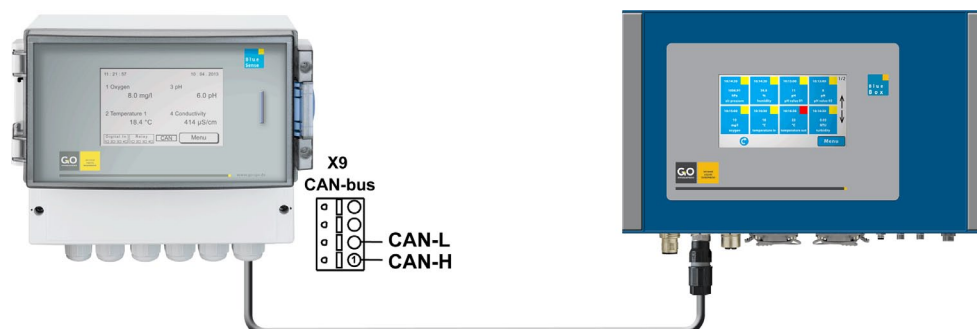

Connect the cable to the transducer to CAN-L and CAN-H (see connection diagram page 7 or 8).
 Connect the cable to the BlueBox using a suitable M12 connector.
 The BlueBox identifies the transducer automatically and displays the input and output values.

The serial number of the transducer (see 9 *Info Transducer*) is also the CAN-ID¹ of the transducer for a connected BlueBox (bls + 5 digits).

Sensor-ID = CAN-ID¹ + Sensor number (max. 17 = bls123451 to bls1234517)

Sensor numbers of the transducer in order:

- 1 to 4 connected sensors
- salinity as a computed value from a conductivity measurement²
- 2 pulse inputs
- 4 digital Inputs
- 2 current outputs
- 4 relay outputs

Depending on the number of connected sensors the Sensor numbers of the following sensors or inputs and outputs³ increase or decrease.

¹ In other contexts also called DAM-ID.

² if active / Salinity according to the general formula of the UNESCO for seawater

³ Strictly speaking the outputs are no sensors but actuators. These outputs are controlled by the BlueBox in the status of "Regulation extern" (see 8 *Programs*).

Appendix C - Adjustment of the Touch Display

If the display does not respond correctly or only under high pressure, a display adjustment is necessary.

While switching on power, press display until the notice

"touch adjustment ?
don't touch for normal use"

appears.

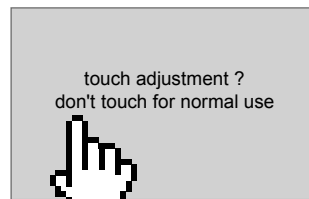
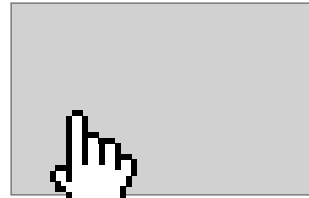

Left off the display immediately!

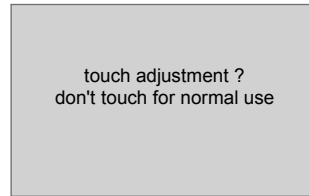

Press the display immediately again for more than one second.

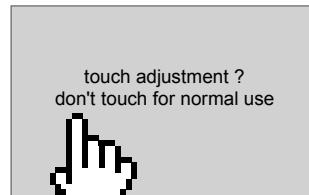

A blinking dot appears at top left.
Press the blinking dot top left.

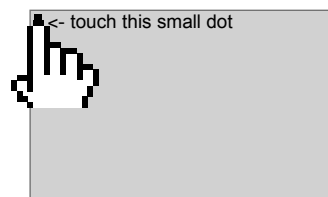

A blinking dot appears at bottom right.
Press the blinking dot bottom right.

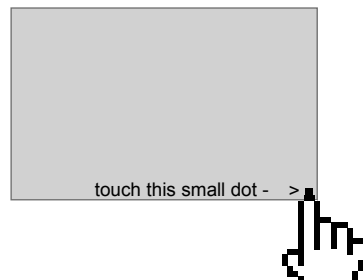

The adjustment is finished.

BlueSense - Housing Dimensions

Appendix D - Housing Dimensions

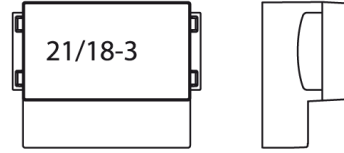
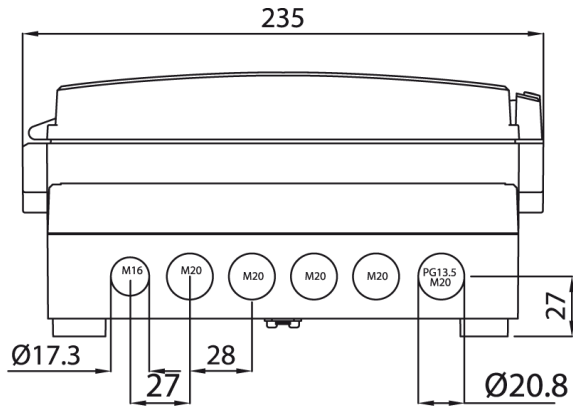

5 x M20 + M16

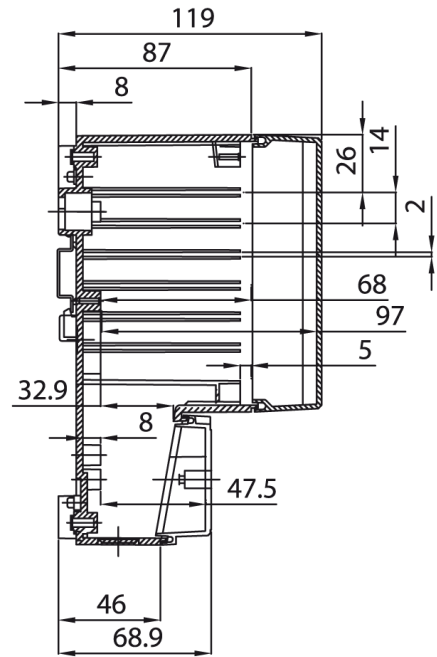
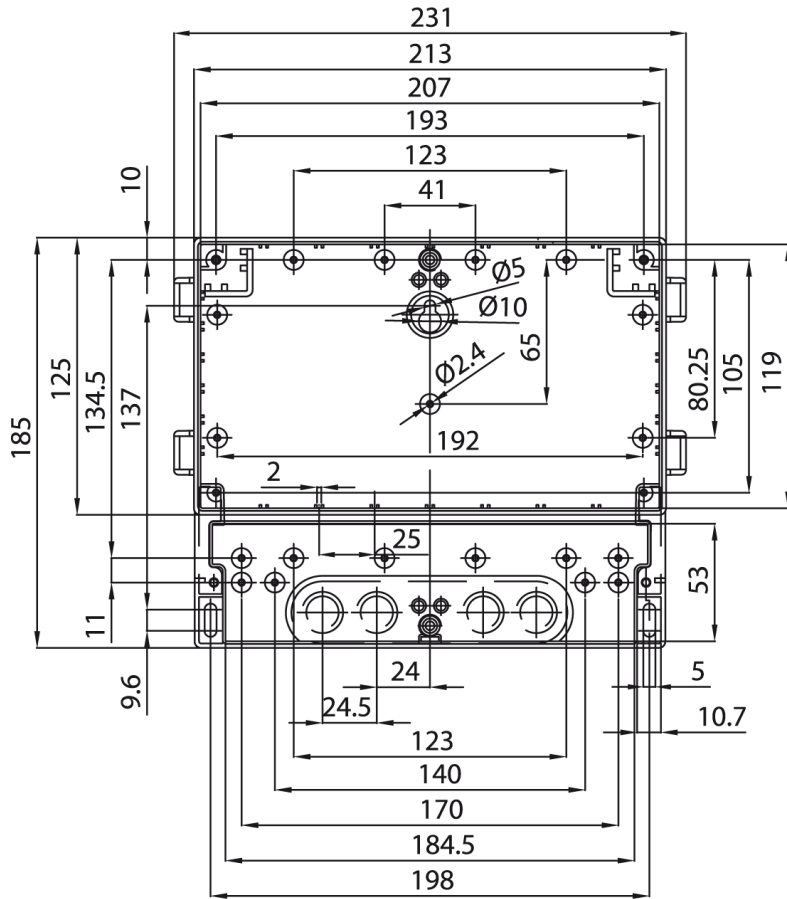

21/18-3

Appendix E - Status and Error Messages

1 Status messages

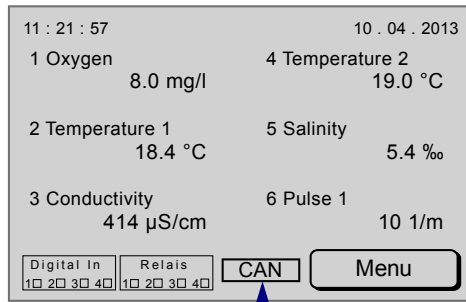

Status messages appear at the bottom of the Parameter Display.



- yet no bus connection is detected



- flashing: CAN-bus card is detected, CAN-bus speed is still unknown



- CAN-bus speed detected (here 50 kbit/s), device is registered on the CAN-bus
flashing: CAN-bus connection is disconnected

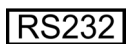

- RS232 card is detected.

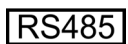

- RS485 card is detected.

2 Error messages

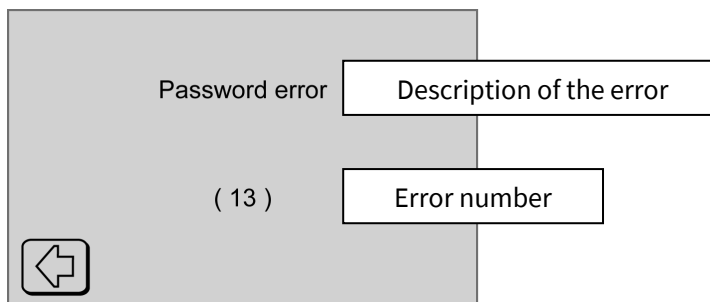

Error messages appear in a separate menu.
The backlight of the display flashes.



Switches back to the previous menu.

Password error	<ul style="list-style-type: none"> incorrect password input 	Entry into csv-file: 4096
(13)		
Communication error!	<ul style="list-style-type: none"> The connection between the motherboard and the display is interrupted. 	Entry into csv-file: 32768
(10)		
Error during data record!	<ul style="list-style-type: none"> SD Memory Card error during a recording 	Entry into csv-file: 16384
Please check memory card.		
(50)		
No memory card found!	<ul style="list-style-type: none"> SD Memory Card missing 	
(99)		
critical battery voltage	<ul style="list-style-type: none"> The supply voltage has dropped below 11.5 volts. 	Entry into csv-file: 2048
(11)	<p><i>If the supply voltage is below 11 V, the transducer will be switched off.</i></p>	
	<ul style="list-style-type: none"> no error 	Entry into csv-file: 0

At combined errors, the error sum is entered in the csv-file.

BlueSense - Multipoint Calibration

Appendix F - Multipoint Calibration

Multipoint calibration, example turbidity¹

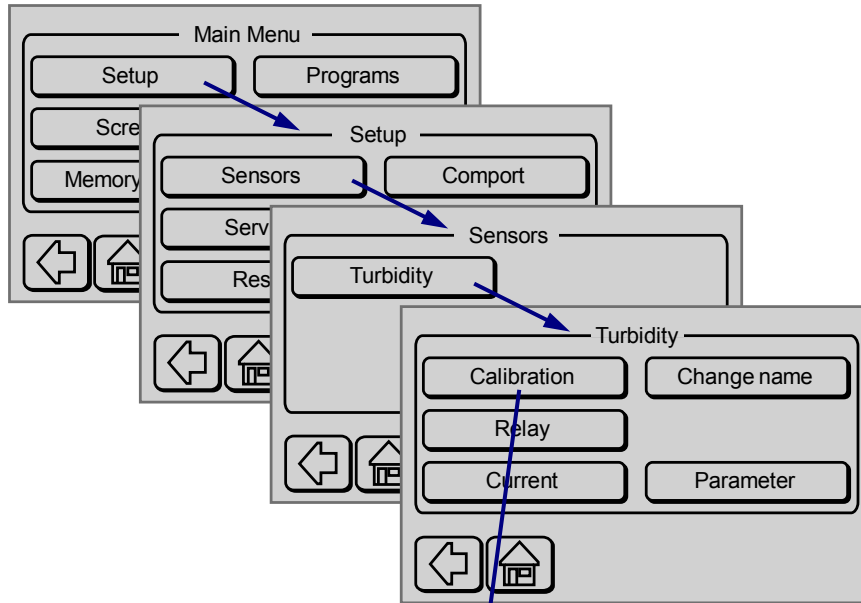

1. Request

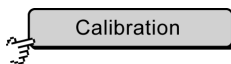

 Activation of the calibration menu

2. Input of the measurement points²

Here you enter the number of measurement points.

-  Switches back to the turbidity menu without saving the input.
-  Deletes the last entered character.
-  Saves the input and switches back to the next menu. Without input the value is set to 2.

¹ Another examples would be a variety of ISE sensors.

² At some sensors there is before a menu for selecting a gain.

BlueSense - Multipoint Calibration

3. Input of the calibration values

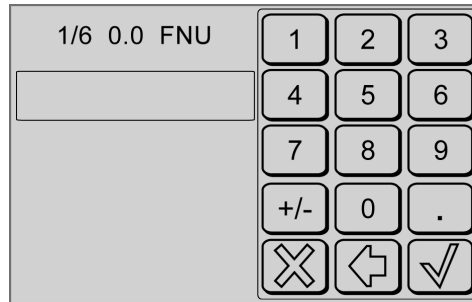

Immerse the sensor into the calibration medium. Enter the turbidity value of the calibration medium.

1/6 actual number of the measurement point / number of measurement points

0.0 actual measurement value and therefore reference value, here 0.0

FNU unit of the measurement, here FNU for turbidity



Aborts the calibration and switches back to the turbidity menu.



Deletes the last entered character.



Saves the input and switches to the next menu.
Without a setting the value is set to 0. Not recommended!

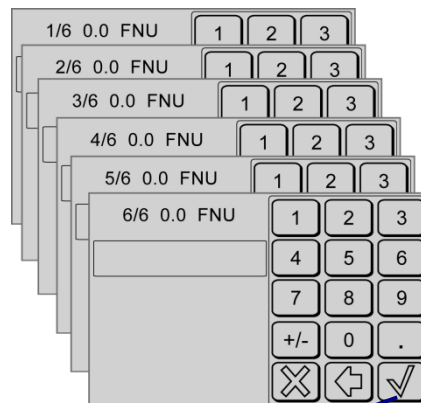

4. Finalizing the calibration

Number	Reference value	Input
1.	n.nnnnn	n.nnnnn
2.	n.nnnnn	n.nnnnn
3.	n.nnnnn	n.nnnnn
4.	n.nnnnn	n.nnnnn
5.	n.nnnnn	n.nnnnn
6.	n.nnnnn	n.nnnnn

List menu:
List of Reference values
List of Input values



Aborts the calibration and switches back to the turbidity menu.



Saves the in calibration and switches back to the turbidity sensor menu.

The calibration is saved and completed.

Appendix G - Menu Structure

Main structure

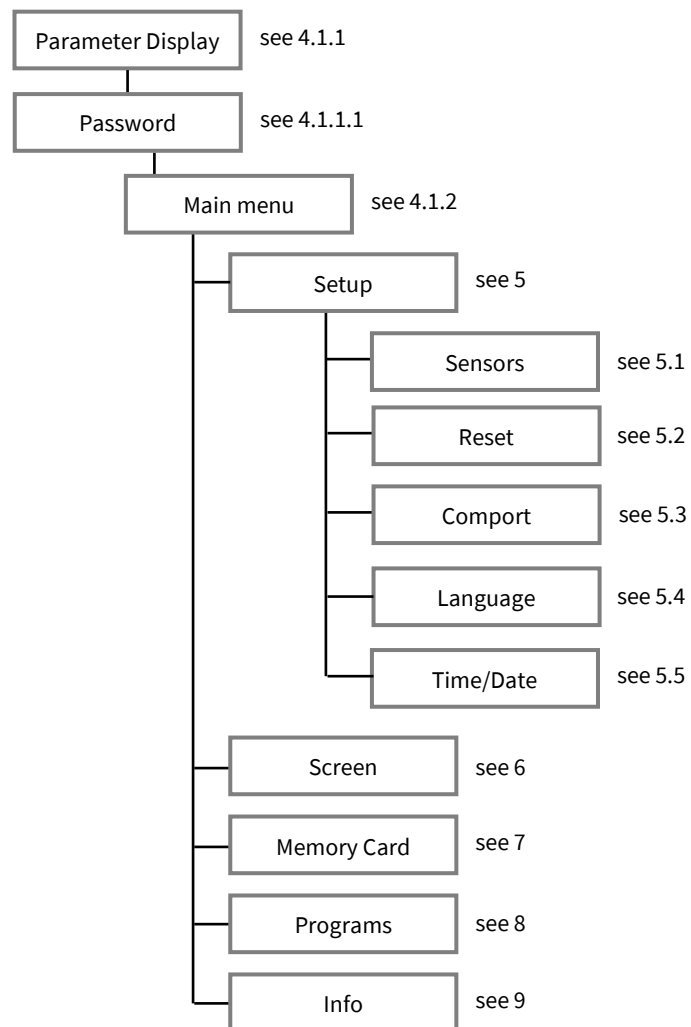

BlueSense - Menu Structure

Sensors

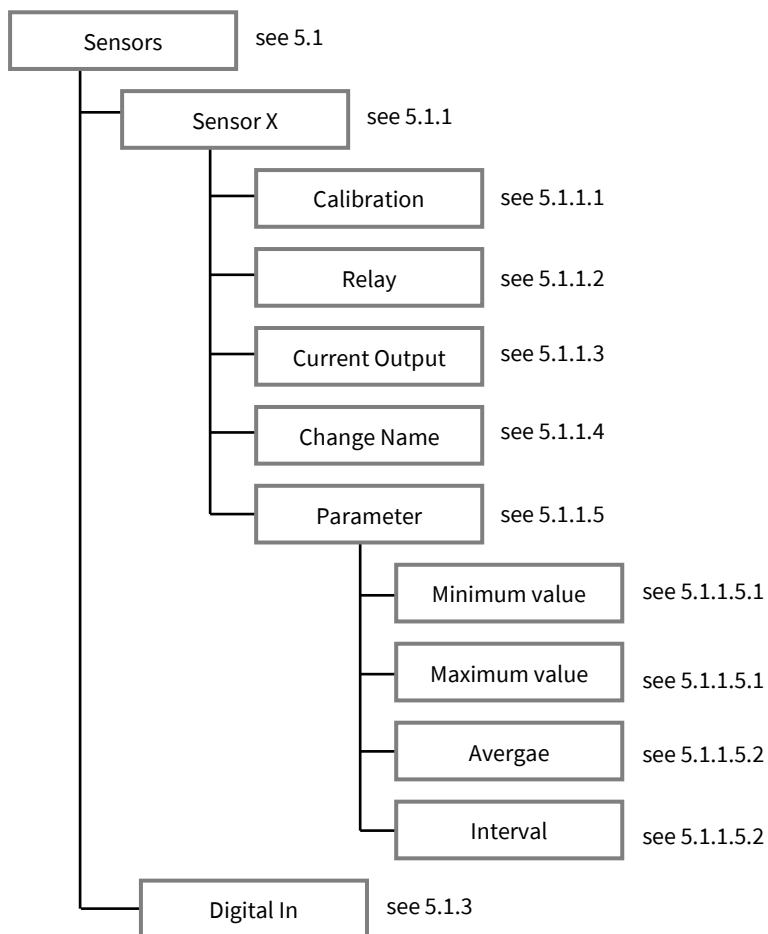

Comport

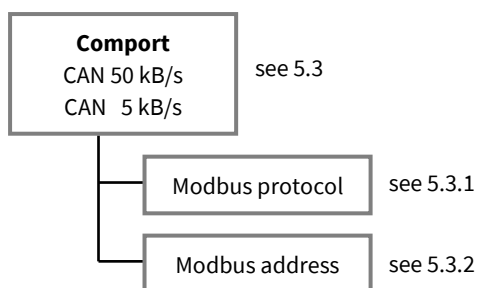

Memory Card

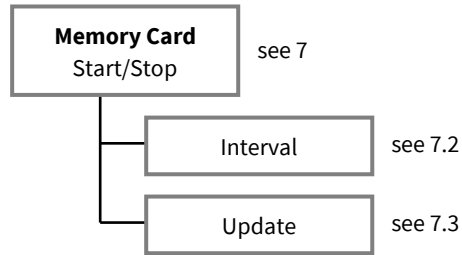

Programs

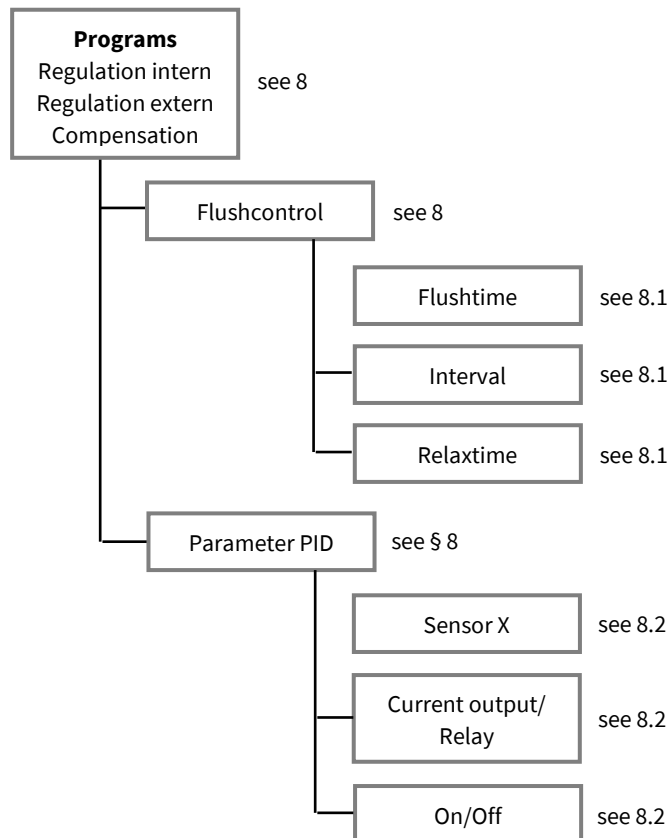

Manual

Commissioning of the BlueSense Transducer

Creation date: 30.6.2021

©GO Systemelektronik GmbH



This manual is an independent part of the *Manual BlueSense Transducer* version 4.9 en and describes the commissioning of the BlueSense Transducer from GO Systemelektronik.

Comprehensive documentation of the BlueSense Transducer can be found on the SD card enclosed with the delivery.

References without a document name refer to the *Manual BlueSense Transducer*, of which this manual is a part.

The products of GO Systemelektronik are constantly being developed, therefore deviations between this manual and the delivered product can result. Please understand that no legal claims can be derived from the contents of this manual.

To determine if your Transducer has 1 or two 2 control parameters please refer to the shipping note, the serial number of the transducer is on the right hand side of the housing.

GO GO Systemelektronik GmbH Made in Germany		CE
Type: BlueSense	Art. No.: 485 0001	
Power supply:	230 VAC	
SN: 1234	39/27	
<small>GO Systemelektronik GmbH 24109 Kiel Tel.: +49 431 58080-0 Fax: +49 431 58080-11 info@go-sys.de ww w.go-sys.de</small>		

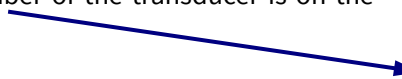

CBB 1 Notes on Operation



Improper handling of electrical devices endangers man and property. Let carry out the commissioning of the device only by skilful, trained personnel using appropriate tools. Incorrect installation could cause serious faults and errors that may damage the device.



Keep this manual handy for future reference. Never deliver the device to other persons without this manual. The manufacturer is not liable for improper or unintended usage.

This device is designed in accordance with the Low Voltage Directive and the safety regulations for electronic measurement devices.

The trouble-free operation and reliability can only be assured if you pay attention to the generally applicable safety measures and special safety instructions in this manual.

- Before the connection of the device to the power supply make sure that the labelled device operating voltage matches the supply voltage (indicating the areas of power supply).
- The correct functioning and operational safety of the device can only be ensured, if the ambient conditions that are specified in the section 2.1 Technical data are complied.
- If the device is transported from a cold to a warm environment condensation may result in a failure of the function. In this case, wait until the device temperature is at the level of the ambient temperature before a new start-up.
- Maintenance and repair work may only be performed by a specialist who is authorized by GO Systemelektronik.

If it is to be assumed that the device can no longer be operated safely, it must be put out of operation and secured with identification markings against further commissioning.

The safety may be compromised by the device if, for example, the device:

- has visible damages,
- no longer works as required,
- has been stored in improper conditions for a longer time,
- was exposed to improper transport conditions.

In cases of doubt give notice to GO Systemelektronik GmbH. If necessary send the device to GO Systemelektronik for reparation respectively maintenance.



Earth the BlueSense Transducer at slot X10.
This is the only way to ensure trouble-free measurement operation.

CBS 2 Commissioning

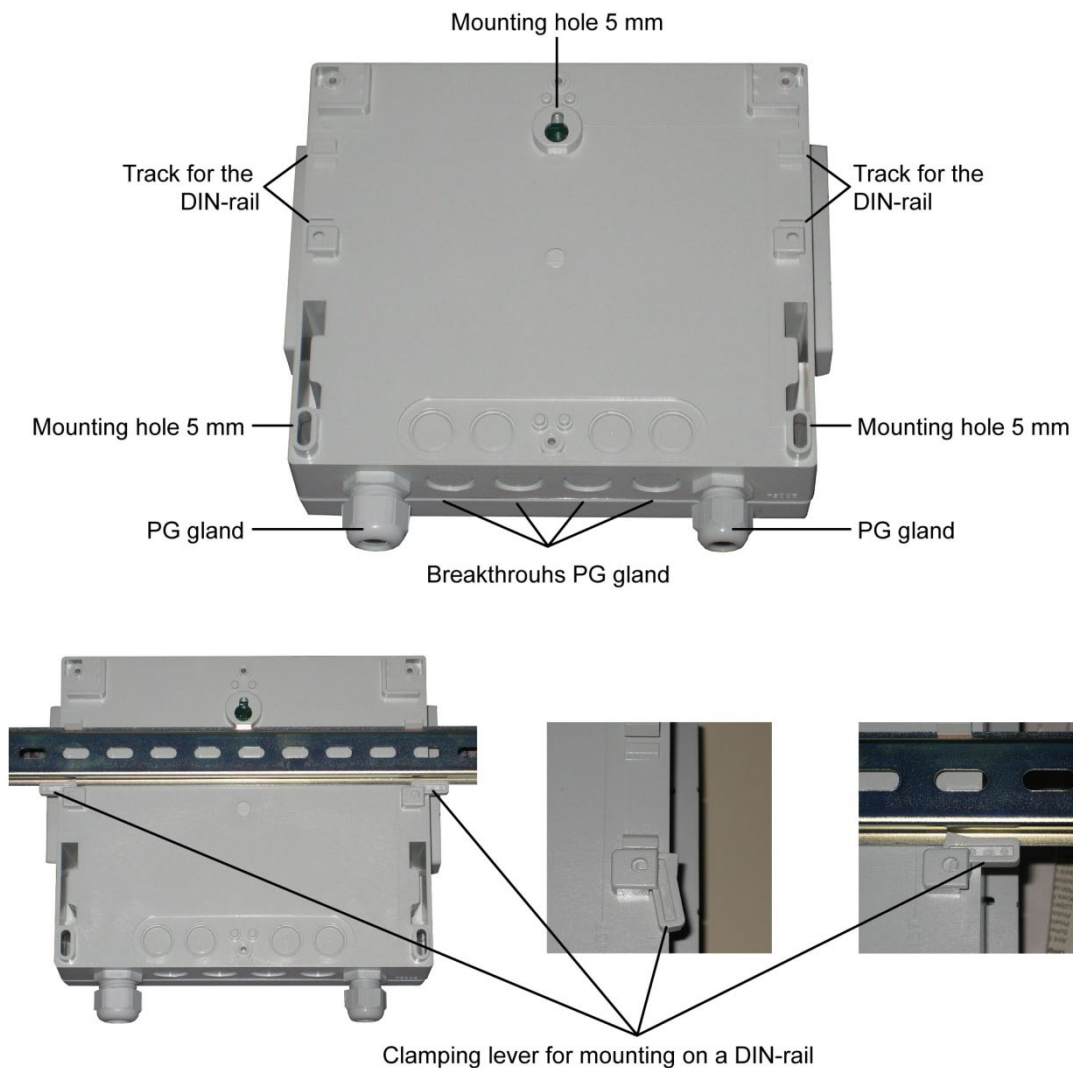

The Transducer's respective sensors, supply voltage, current outputs and, where applicable, the relays, are to be connected via the spring-loaded connectors. The terminals are marked.

see 2.2 *Connection Diagram 1 Control Parameter* or 2.3 *Connection Diagram 2 Control Parameter* and 2.4 *Sensor Terminal Connection Diagram*

 To avoid incorrect measurements, the PE contact of the power supply (slot X10) must be connected.

The cable entry is via the PG glands.

To-do list after initial start-up:

- language setting: see 5.4 *Language setting*
preadjustment: english
- time setting see 5.5 *Time Date*
preadjustment: timezone of the customer
- if applicable sensor calibration
e.g. for ISE sensors
- customer-specific settings
relay settings (switching and hysteresis values), current output settings, etc.
- if applicable adjustment of the touch display
The touch-panel is adjusted and ready for use. A long storage by the customer may cause the necessary of a new adjustment (see *Appendix C - Adjustment of the Touch Display*).

CBS 3 EU Declaration of Conformity



**EU-Konformitätserklärung
EU Declaration of Conformity**

Hersteller: GO Systemelektronik GmbH
Manufacturer: Faluner Weg 1
24109 Kiel Germany

Die alleinige Verantwortung für die Ausstellung dieser Konformitätserklärung trägt der Hersteller.
The sole responsibility for issuing this EU declaration of conformity is carried by the manufacturer.

Gegenstand dieser Erklärung: BlueSense Messumformer
Subject to this declaration: BlueSense Transducer

Artikelnummer: 485 0001
Article No.:

Typenschild des Produktes:
Type plate of the product:

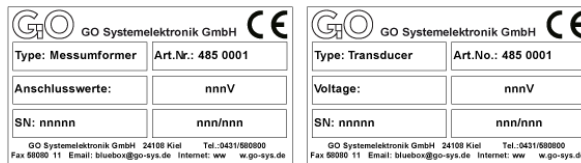

Der oben beschriebene Gegenstand der Erklärung erfüllt die einschlägigen Harmonisierungsvorschriften der Union.
The subject matter described above fulfills the relevant harmonization rules of the Union.

Zugrunde liegende harmonisierte Normen:
Underlying harmonized standards:

1. DIN EN 61000-6-3:2011 Störaussendung *Interference emission*
2. DIN EN 61000-6-1:2007 Störfestigkeit *Interference resistance*

(Falls zutreffend) **Gemäß den Bestimmungen der Richtlinie/den Dokumenten:**
(If applicable) Following the provision of directive/the documents:

1. DIN EN 60950:2006 Niederspannungsrichtlinie *Low voltage directive*
2. Fertigungs- und Prüfanweisung BlueSense Messumformer PA 485 0001
Manufacturing and test instruction BlueSense Transducer PA 485 0001
3. Bedienungsanleitung BlueSense Messumformer *Manual BlueSense Transducer*

Kiel, 20.6.2017
Ort, Datum der Ausstellung
Place, date of issue



Dr. Thorsten Knutz
Geschäftsführer *Managing director*

GO Systemelektronik GmbH Faluner Weg 1 24109 Kiel Germany Tel.: +49 431 58080-0 Fax: -58080-11
www.go-sys.de info@go-sys.de **Seite Page 1 / 1**